

1994

Menstrual technology in the United States, 1854 to 1921

Laura Klosterman Kidd
Iowa State University

Follow this and additional works at: <https://lib.dr.iastate.edu/rtd>

 Part of the [American Studies Commons](#), [Women's History Commons](#), and the [Women's Studies Commons](#)

Recommended Citation

Kidd, Laura Klosterman, "Menstrual technology in the United States, 1854 to 1921 " (1994). *Retrospective Theses and Dissertations*. 10617.
<https://lib.dr.iastate.edu/rtd/10617>

This Dissertation is brought to you for free and open access by the Iowa State University Capstones, Theses and Dissertations at Iowa State University Digital Repository. It has been accepted for inclusion in Retrospective Theses and Dissertations by an authorized administrator of Iowa State University Digital Repository. For more information, please contact digirep@iastate.edu.

9 4

2

4

2

3

1

U·M·I
MICROFILMED 1994

INFORMATION TO USERS

This manuscript has been reproduced from the microfilm master. UMI films the text directly from the original or copy submitted. Thus, some thesis and dissertation copies are in typewriter face, while others may be from any type of computer printer.

The quality of this reproduction is dependent upon the quality of the copy submitted. Broken or indistinct print, colored or poor quality illustrations and photographs, print bleedthrough, substandard margins, and improper alignment can adversely affect reproduction.

In the unlikely event that the author did not send UMI a complete manuscript and there are missing pages, these will be noted. Also, if unauthorized copyright material had to be removed, a note will indicate the deletion.

Oversize materials (e.g., maps, drawings, charts) are reproduced by sectioning the original, beginning at the upper left-hand corner and continuing from left to right in equal sections with small overlaps. Each original is also photographed in one exposure and is included in reduced form at the back of the book.

Photographs included in the original manuscript have been reproduced xerographically in this copy. Higher quality 6" x 9" black and white photographic prints are available for any photographs or illustrations appearing in this copy for an additional charge. Contact UMI directly to order.

U·M·I

University Microfilms International
A Bell & Howell Information Company
300 North Zeeb Road, Ann Arbor, MI 48106-1346 USA
313/761-4700 800/521-0600



Order Number 9424231

Menstrual technology in the United States: 1854 to 1921

Kidd, Laura Klosterman, Ph.D.

Iowa State University, 1994

Copyright ©1994 by Kidd, Laura Klosterman. All rights reserved.

U·M·I
300 N. Zeeb Rd.
Ann Arbor, MI 48106

**Menstrual technology in the United States,
1854 to 1921**

by

Laura Klosterman Kidd

**A Dissertation Submitted to the
Graduate Faculty in Partial Fulfillment of the
Requirements for the Degree of
DOCTOR OF PHILOSOPHY**

**Department: Textiles and Clothing
Major: Textiles and Clothing**

Approved:

Signature was redacted for privacy.

(In Charge of Major Work

Signature was redacted for privacy.

For the Major Department

Signature was redacted for privacy.

For the Graduate College

**Iowa State University
Ames, Iowa**

1994

Copyright © Laura Klosterman Kidd, 1994. All rights reserved.

TABLE OF CONTENTS

ACKNOWLEDGEMENTS	iii
CHAPTER 1. INTRODUCTION	1
CHAPTER 2. REVIEW OF LITERATURE	8
CHAPTER 3. DATA COLLECTION AND PATENT ACTIVITY	23
CHAPTER 4. DESIGN AND MATERIALS IN MENSTRUAL TECHNOLOGY	35
CHAPTER 5. AVAILABILITY AND MARKETING OF MENSTRUAL TECHNOLOGY	80
CHAPTER 6. REASONS FOR THE PATENTING OF MENSTRUAL PRODUCTS	125
CHAPTER 7. MENSTRUAL TECHNOLOGY AND WOMEN'S DRESS	134
CHAPTER 8. MENSTRUAL PRODUCTS AND THE WORKING WOMAN	142
CHAPTER 9. MEDICAL PRACTITIONERS AND MENSTRUAL TECHNOLOGY	151
CHAPTER 10. SUMMARY AND CONCLUSIONS	155
REFERENCES	168
APPENDIX A. LIST OF WOMEN'S DIARIES	176
APPENDIX B. MENSTRUAL PRODUCT PATENT LIST, 1854-1921	178
APPENDIX C. ADJUSTMENTS TO PATENTEE NUMBERS	206
APPENDIX D. REGIONAL DIVISIONS BY STATE	207
APPENDIX E. NAMES OF MENSTRUAL PRODUCTS FROM THE PATENTS	208
APPENDIX F. DISPOSABLE MENSTRUAL PRODUCT PATENTS	209
APPENDIX G. SAFETY PINS IN MENSTRUAL PATENTS	211
APPENDIX H. CATAMENIAL GARMENTS	212
APPENDIX I. MENSTRUAL RETENTIVE CUPS	213
APPENDIX J. LIST OF ASSIGNED PATENTS	214
APPENDIX K. LIST OF PATENTS THAT MENTION DRESS OR FASHION	216

ACKNOWLEDGEMENTS

Many thanks to the following people, who, through their patience and cooperation, helped make the successful completion of this dissertation possible: the faculty and staff of the Department of Textiles and Clothing at Iowa State University, in particular LuAnn Gaskill, Sara Kadolph, and Geitel Winakor; Dorothy Schwieder and Dahlia Stockdale; the Department of Human Resources at the University of Hawai'i-Manoa and the faculty and students in the Fashion Design and Fashion Merchandising Program; Tom and Michael, our families and friends; Sarah Cosbey; and a very special thanks to Jane Farrell-Beck, who not only was my major professor, but is a real friend, one of infinite patience and great wit.

CHAPTER 1

INTRODUCTION

The female reproductive cycle--menstruation, pregnancy and menopause--has been a source of fascination for centuries. In particular, menstruation and the cultural, anthropological, and sociological perceptions surrounding this physiological act, have been extensively studied and written about, particularly in the latter half of the twentieth century (Buckley & Gottlieb, 1988; Delaney, Lupton & Toth, 1976/1988; Showalter & Showalter, 1972; Shuttle & Redgrove, 1978; Vertinsky, 1990; Weideger, 1975). No less fascinating are the many types of menstrual technologies that have been developed and used to manage the menstrual discharge.

Information is scarce concerning menstrual technology. Historians agree most women used diaper-like pieces of cotton fabric or cotton rags during their menstrual periods (Brownmiller, 1984; Delaney et al., 1976/1988; Faragher, 1979/1991; Luchetti, 1982). Further scholarship revealed that mail order houses such as Montgomery Ward; Sears, Roebuck; and Harrod's of London offered sanitary protection devices for sale (Cohn, 1940; Delaney et al., 1976/1988; Schroeder, 1976). Most investigations into commercial sanitary protection products concentrate on the twentieth century, focusing on the advent of disposable menstrual pads (Busch, in press), the growth of sanitary protection into a big business (Delaney et

al., 1976/1988; Palmer & Greenberg, 1936), and the effects of improved sanitary protection on feminine emancipation and fashion (Schroeder, 1976).

The concentration of many researchers on twentieth century sanitary products may be due, in large part, to the paucity of information on products developed before the twentieth century. Very little appears to be known about what may have come between the use of cotton rags and the types of products available through mail order houses. I could find no comprehensive study on the types of sanitary protection products developed or created for women in the United States before the introduction of the Kotex® disposable sanitary napkin in 1920. Furthermore, in previous research, there is no indication of any type of product development or logical progression of product design that resulted in the Kotex® sanitary napkin. The purpose of this research was to attempt to discover and document the types of products being developed for commercial use for women in the United States before 1921.

Research Questions

From preliminary reviews of the available literature, I developed the following research questions:

1. What was the perception of women's needs for sanitary protection during the nineteenth century? Could these perceptions aid or hinder the research into the development of these products?

2. Did the emergence of women into the work force appear to affect the development of sanitary protection products? From the available evidence, is there any indication of the personal or public needs of women in the United States during the nineteenth century influencing the development of these products?
3. Did medicine or medical attitudes appear to have a role in the development of sanitary protection products?
4. How were sanitary protection products presented to the public?
5. Were there any parts of women's dress that appear to have been influenced by development of sanitary protection products?

Assumptions

The available evidence will present an accurate picture of the kinds of feminine sanitary protection devices and products that were being developed in the United States during the nineteenth and early twentieth centuries.

Limitations

The following limitations apply to this study:

1. Research will be limited to development of feminine sanitary protection products in the United States, from 1790 to 1921.
2. Actual sanitary protection devices and products from 1790 to 1921 will most likely not be extant or available to

the researcher. Therefore, this study will be limited to written or printed documentation as evidence of these products.

3. This study is limited to those items mentioned specifically to be used for menstruation. The tampon is excluded from this study. Although patents for tampons were found, and there is evidence that the tampon was used medically during the time under investigation, there was no indication that these items patented during the nineteenth and early twentieth centuries were created for use in the management of the menstrual discharge.
4. All calculations and counts performed for this study were done by the researcher, and are subject to human error. However, every attempt was made to be as accurate as possible.

Operational Definitions of Terms

Feminine sanitary protection products: Any product developed for the absorption of the menstrual discharge.

Lochia: The discharge from the uterus for several weeks after childbirth.

Medicament: A drug, remedy, or anything used for curing, healing or relieving pain.

Menstrual technology: Inventions, products, or innovations created for use in menstrual management (adapted from Stanley, 1993).

Orthodox medicine: Traditional, mainstream medicine.

Pessary: An instrument placed in the vagina to support a displaced or weak uterus; some types were used as contraceptive devices.

Sectarian medicine: Health care that included such practices as botanical and eclectic medicine and hydropathy (water cure).

Procedures and Methods

Because the products investigated were used for the management of menstruation, the logical place to begin research for my review of literature was medical and prescriptive writings on menstruation and menstrual products. Primary sources consisting of medical texts and medical writings were located; these medical writings were from orthodox, as well as sectarian branches of medicine. I also read other primary sources, such as women's diaries, particularly diaries of "western women." For data collection, United States patents from 1790 through 1921 were examined. Available women's journals from the nineteenth century were surveyed for articles dealing with health as well as for advertisements for commercial menstrual products. I also searched for writings on women's health concerns from the nineteenth century, consisting of physical education and hygiene manuals and books. Secondary current scholarship on nineteenth century medicine, menstruation, and women was also studied.

I encountered many problems during my research for the review of literature. Many primary source materials, such as women's periodicals and books published in the nineteenth century, were not available for borrowing through interlibrary loan. And, in many instances, the periodicals that were available were bound or filmed without their advertisement sections. Fortunately, I was able to utilize two university libraries, the Parks Library at Iowa State University and the Hamilton Library at the University of Hawai'i-Manoa. To my surprise and delight, the collections complemented my research, and with a few exceptions, I was able to obtain most of the primary materials that I needed.

Organization of the Dissertation

This dissertation is divided into clearly titled chapters that indicate the main topic of each section. Chapter 1 is a description of the research questions and procedures that guided my study. Chapter 2 is a synopsis of the review of literature that was performed. Chapter 3 is a presentation of patenting activity by sex and geographic divisions. Chapter 4 describes the design and materials used in the creation of menstrual products; Chapter 5 discusses the availability and marketing techniques of menstrual products. Chapter 6 considers reasons for product development. In Chapter 7, the possible relationship between menstrual products and changes in women's fashions is presented. Chapter 8 explores

occupational health literature related to menstruation. Chapter 9 examines the role that medical practitioners may have played in the development of menstrual products. Chapter 10 is the concluding chapter of this dissertation, and is a summary of my findings, as well my recommendations for further research.

CHAPTER 2

REVIEW OF LITERATURE

Medical Writings and Menstruation

I first reviewed medical writings about menstruation in an attempt to discover if medical practitioners ever instructed women on how to manage the menstrual flow. Because this study was limited to U.S. menstrual technology, medical literature used or written by medical practitioners in the United States was considered most relevant to the topic. Because most medicine in the Western tradition is based on ancient Greek medical literature, the works of Soranus were first consulted.

In his tract on gynecology, Soranus mentioned menstruation; of particular concern was the cessation of the menstrual flow. He also gave prescriptive advice that the menstruating woman not exert herself, practice "passive exercise," massage with "fat," and take a daily bath on the second and succeeding days of menstruation (Temkin, 1956, p. 21). Soranus only offered advice on behavior during menstruation; he was silent on how the menstrual discharge should be managed.

Soranus referred to the use of the vaginal tampon, as did medical writers of ancient Mesopotamia (Adamson, 1991). In both instances, tampons were not suggested for use during menstruation, but as an aid in surgery or to stanch uterine

hemorrhaging. Soranus advised constructing tampons or vaginal suppositories out of a piece of wool which had been soaked in sweet, warm olive or linseed oil or some other fatty creams (Temkin, 1956). Mesopotamian medical prescriptions for tampon material recommended the use of wool, horse hair, or cotton wool taken from the "cotton tree" (Adamson, 1991, p. 433).

Delaney et al. (1976/1988) contended that Indonesian women and Roman women used tampons; the authors implied that the tampons were used for menstruation. Nowhere in the review of literature or in the patent search was there any reference or suggestion that implied tampons, as developed in the Western tradition, were used during menstruation before the twentieth century. This does not mean inventive pre-twentieth century women did not use vaginal tampons during menstruation. However, because the data collected did not report that tampons were being developed for use in menstrual management, these items were not considered in this investigation.

I found a recently published translation of a tract on medieval gynecology (Rowland, 1981). Written in Middle English, the identity and sex of the original author of the tract is unknown. Menstruation or "bleeding" (p. 59) was discussed in this tract, and there was a realization that menstruation occurred on a regular basis and that it stopped during pregnancy. In general, however, menstruation remained a mystery.

As in Greek times, the cessation of the menses in a woman who was not pregnant was considered a potentially serious medical condition. Vaginal suppositories used four or five days before the "time of the month" (p. 69) were believed to rectify this situation. One such suppository consisted of

...half a drachm of triacle diatesseron [a medicament with 4 ingredients], the same amounts of cockle flour and myrrh, and grind them together with bull's gall in which savin or rue has been rotted. And then cover the mixture with cotton and thereof make a suppository as large as your little finger...(Rowland, 1981, p. 69)

But absolutely nothing was mentioned about what the medieval woman used during the actual menstrual flow.

Although I located no primary source for medical practices concerning menstruation for the Tudor and Stuart periods (the sixteenth and seventeenth centuries), I did discover an historical study based on primary source obstetric and gynecological writings. Eccles (1982) found that menstruation was universally misunderstood by educated and uneducated alike. Menstruation was regarded as essential to health, however. No reference was made to items that were used in menstrual management. Pessaries were recommended for married women to use in the case of the cessation of the menses; "fumigations" were considered as more appropriate for virgins (p. 75). Eccles found evidence that condoms and the contraceptive sponge were used during the seventeenth century, but could locate no medical writings that described or endorsed the use of those items.

No information concerning menstrual technology could be located for the eighteenth century. I started to review writings about midwives and midwifery, attempting to find primary source material that suggested midwives helped women during menstruation or menopause. I looked for references for any mention of products or garments used to absorb the lochia, hoping to find a connection between lochial products and menstrual products.

I found references to midwife manuals, such as the *Textbook of Midwifery* (1595), *The Compleat Midwife's Companion* by Jane Sharp (1600s), David Spence's *A System of Midwifery Theoretical and Practical* (1784), and the *Domestic Midwife* by Margaret Stephen (1795), but none of these texts were available for study. A review of recent historical studies on midwifery revealed that major trends in research are the ramifications of the switch from female midwives to male doctors, or the childbirth experience as a part of women's social history (Donegan, 1978; Kobrin, 1966/1984; Leavitt & Walton, 1981/1984; Litoff, 1978; Scholten, 1977/1984; Towle & Bramall, 1986). During a library search, I discovered a periodical published in London from 1750 to 1753 entitled *Midwife; or, Old Woman's Magazine*. Full of topical items, such as theatre articles and excerpts from sermons, it made not one mention of health items or childbirth in any issue.

Apparently, most midwives did not keep diaries or written records of the services they performed. An exception was Martha Ballard, a midwife who practiced in the United States and kept a diary from 1785 to 1812. Although I could not procure the entire diary, excerpts were available in a biography of Martha Ballard's life. Ulrich (1990) discovered that midwives, like Martha Ballard, treated not only general illnesses of women and children, but also "touched the untouchables" (p. 47), ministering to illnesses such as obstructed menstruation. Although Martha Ballard did not specifically mention menstrual products, she did refer to using "fine linning raggs [sic]" (p. 95) after childbirth to absorb the lochia.

Orthodox and sectarian medical men who wrote about midwifery in the 1850s were no more informative than Ballard about menstrual items. Dr. Joel Shew, a sectarian proponent of the water-cure treatment as well as an advocate of man-midwifery, prescribed management during menstruation, encouraging bathing, exercise, attention to diet, as well as "cheerfulness, contentment, and a pleasing frame of mind" (Shew, 1852, p. 41). Although he wrote about the lochial discharge, he neglected to mention any absorbent device that might have been used. Dr. Frederick Hollick (1853), an orthodox practitioner, gave no instruction for absorbing the menstrual discharge, but did recommend that, after delivery,

"warm napkins should be placed under the pelvis and between the limbs, to soak up the discharge" (p. 242).

Schroeder (1976) contended that, before 1921, behavior patterns surrounding menstruation in the United States were perpetuated by the "female underground" (p. 103) and information concerning sanitary products and devices was most probably passed by the spoken word, woman-to-woman. Given the close and often intense relationships between women during the nineteenth century (Smith-Rosenberg, 1975/1991), it is probable that information about a number of different topics was shared; certainly menstrual management was among them. One of the most intimate woman-to-woman relationship was mother-to-daughter. Many authors assigned the task of communicating hygienic information concerning menstruation to mothers, assuming that mothers instructed their daughters about menstruation (Blackwell, 1858; Law & Law, 1899/1908; Shew, 1852). The construction of items used in menstrual management was also assumed to have been taught by mothers ("Modern Hygiene," 1930). I found evidence that suggested this may not have been as customary a practice as assumed.

Dr. Mary Wood-Allen, in the preface to her book *What A Young Girl Ought to Know* (1905) stated she wrote this book because many girls are not instructed in "puzzling problems" (p. 17), one of which may have been the management of menstruation. As a means of instruction, she prescribed

behavior during menstruation, and described a type of menstrual item.

As a minor item, I would suggest that the napkins be fastened to straps that go over the shoulder and are then joined together in front and back to an end piece, on each of which a button is sewn. Buttonholes in the napkins at the corners, diagonal from each other, will make them easily attached or removed. The napkins should be of a material that is quickly absorbent of the flow. Cheesecloth is cheap, and can be burned or otherwise disposed of after using. It may be protected by an outer strip of unbleached muslin which is almost water-proof.

A very comfortable way of arranging napkins that are to be used from time to time is to take a piece of linen or cotton diaper sixteen inches square. About three inches from one end, make on each side an incision four inches long. Fold this strip in the middle lengthwise, and sew together up to the end of the incisions. This makes a band with sort of pocket in the middle. Hem the cut edges. Fold the napkin over, four inches on each side, that is as deep as the incisions. Then fold crosswise until you can enclose the whole in the pocket in the band. This makes a thick center and thin ends by which to attach the napkin to the suspender (Wood-Allen, 1905, p. 149)

This is the only written reference I could find in my review of literature that described a menstrual product in such detail.

I found evidence that homemade devices for menstrual management were developed earlier than Wood-Allen's. The Valentine Museum, located in Richmond, Virginia, has in its collection a knitted sanitary napkin and belt (C. Callahan, personal communication with J. Farrell-Beck, March 19, 1992). According to the accession card, these artifacts are dated circa 1850s. The napkin is a knitted strip of coarse cotton yarns, tapering at both ends, with a buttonhole in the shorter

end, and is approximately 25 inches long and 2 1/2 inches wide. The belt is a double strip of coarse cotton fabric, tapering to a squared end, with buttonholes at the broad end and approximately 2 inches from the narrow end. The belt is roughly 24 inches long, and varies in width from 1/2" to 1". The design and shape of the napkin exhibit a sophistication beyond that of the cotton rags or diapers usually considered as the only sanitary protection products available to women at this time. Unfortunately, further information is missing on how this homemade product was developed. Other than Wood-Allen's directions (1905), I located no source of instruction for making sanitary protection products. No medical writer made a link between items to be used after childbirth to absorb the lochial discharge and items to be used during menstruation. Perhaps this was meant or understood to be "common knowledge." "Bandages" mentioned in prescriptive literature were revealed to be pregnancy supporters (Rowland, 1981; Temkin, 1956) or post-partum supporters, "to preserve the form after childbirth" (Napheys, 1870, p. 186, 204).

In my review of available pre-twentieth century medical writings, I could find no information specifically about the management of menstruation. This seemed rather curious, considering the near-obsession the medical profession had during the late nineteenth century with the reproductive system in general, and the uterus in particular (Smith-

Rosenberg, 1974; Stage, 1979; Wood, 1973/1984). I then directed my search to private writings, in the form of women's diaries, specifically from the nineteenth century.

Extant diaries of "ordinary" women are difficult to locate. Many women did not keep diaries; those who did often destroyed them. Many remain hidden, perhaps tucked away in old trunks or dusty attics. Fortunately for social historians, more and more of these diaries are being found and published and serve as wonderful sources for glimpses into how women lived their everyday lives. Of particular interest to this study were the diaries of pioneering, homesteading and "westering" women--women who emigrated to the western parts of the United States. Since these women had to perform ordinary functions under extraordinary conditions, I hoped they might have mentioned how they managed menstruation. A complete listing of the diaries examined is located in Appendix A.

My initial investigation of these diaries was undertaken realizing references to menstruation, if present at all, would most likely be indirect. I searched for a series of regular references to headaches or other symptoms that may have been clues the woman was experiencing her menstrual period. Any mention of pregnancy and childbirth was also noted, in hopes there would be a description of some type of item that would have been used to absorb the lochial discharge. In very few

instances, however, did I find any references to menstruation or pregnancy.

References to being "unwell" or having a "sick headache" in some of the diaries (Arpad, 1984; French, 1987; Myres, 1980; Schwartz, 1984), might have indicated that the woman was experiencing menstruation. I plotted those references to see if periods of ill health occurred in cyclical monthly trends. Although these diary entries may have represented the menstrual cycle, I cannot be certain of that fact. The times between references to ill health were either too close together or too far apart to represent the normal menstrual cycle.

In Mary Richardson Walker's diary (Drury, 1963b), her use of the word "sick" (p. 134, 192, 226) as well as references to "her illness" (p.327) are euphemisms for labor and childbirth. Statements in her diary indicated she may "feel very lazy" (p. 263), as well as tired; however, she didn't suggest she was tired because of pregnancy. And from the amount of work she did on a daily basis, noted in her diary, her tiredness may have been job-related. Nowhere in her diary did she mention menstruation, although she was quite candid and informative about the problems she had breast-feeding her children, their development, and her methods of disciplining them. In her candidness about everyday experiences, she was quite unusual in comparison with the other diarists; Drury (1963b) contends

"Mary wrote for her own personal satisfaction" (p. 22), and was freer in her observations.

Menstrual cloths or products were not mentioned in any lists of suggested supplies to be taken by any woman who intended to make the overland journey to the West. Myra Fairbanks Eells and Sarah White Smith, in letters written back East after their arrival in the Oregon Territory, listed clothing they considered as necessary for women journeying across the Rockies. Their lists were very similar, and consisted of minimum essentials in acceptable wardrobe. Undergarments were mentioned by both women; Myra Fairbanks Eells recommended women's "underclothes as well as the gentlemens [sic] should all be colored" (Drury, 1963b, p. 119). Sarah White Smith contended underdrawers should be of a dark color and was adamant in asserting the dark color was "indispensably necessary, white is not only inconvenient as it respects washing, but I consider it altogether improper" (Drury, 1966, p. 125). Neither list included any type of extra cloth or rags as clothing provisions. Women were urged to take only one trunk, 26x15x14 inches, into which all of their personal effects and clothing were to fit (Drury, 1963b). Since these women's average age was 28 years, the majority would most likely have experienced menstruation on a monthly basis. Given the length of the journey (about six months) and the lack of basic necessities, such as cloth, at

their final destinations, menstrual hygiene must have been a problem. Yet, the women never commented on providing for menstruation in either of these lists.

There were some women who did mention menstruation in their diary entries. Writing in 1890, Emily French (1987) noted being "so bad in my periods these days" (p. 82) and "bad with my monthly sickness" (p. 128), a woman having her "menses" (p. 97), and her daughter, Olive, having "periods" (p. 111). Emily Hawley Gillespie also referred to her daughter's first menstruation, and Lensink (1989) believes the notation "!!!" used by Gillespie on certain days signified Gillespie's menstrual periods (p. 368, 401). French's references to menstruation are the exception, not the rule; for the most part, diarists did not mention menstruation at all.

Although this may seem unusual, it must be noted that in most of these diaries, there is also no mention of pregnancy or childbirth until after the fact. With no previous clue that the woman was pregnant, the announcement of the presence of an infant is quite jarring to the reader (to say the least). The diaries of Narcissa Prentiss Whitman, Eliza Hart Spalding, and Mary Richardson Walker are the most vivid examples of this. Whitman made no reference to being pregnant, not even mentioning the March 14, 1837, birth of her daughter until March 30, 1837 (Drury, 1963a, p. 126-127).

Spalding, as well, did not mention the November 15, 1837, birth of her daughter until December 3, 1837 (Drury, 1963a, p. 203). Walker, although making no reference to being pregnant, recorded the date of the birth of each of her children on the day on which the child was born (Drury, 1963b). Perhaps mothers were reticent in mentioning a child's birth because of the high rate of infant mortality characteristic on the frontier. Prevailing nineteenth century views of the reproductive cycle and the ambivalent attitude surrounding the "cycle of femininity" (Smith-Rosenberg, 1974, p. 23) may have also aided in creating an aura of shame which made any mention of these functions, even in a personal diary, inappropriate and unrefined. In addressing the absence of information in these diaries, Schlissel (1982) stated

Perhaps the children were part of that private world that women committed to oral exchanges, talking with one another as the wagons rolled mile after mile on those long, hot days. The realm of children would then have been consigned to the oral tradition along with information about menstruation, marriage, and pregnancy and childbirth. So much of the woman's world was omitted from written accounts--even from the diaries. So much of the woman's world in the nineteenth century was hidden by elaborate taboos (p. 82)

Because there was no mention of menstruation, there was no mention of any type of product used to manage menstruation. One exception was found in the diary of Emily French (1987). In the entry for July 18, 1890, she wrote that she "washed out my cloths, I am so bad in my periods these days" (p. 82). The "cloths" referred to are most probably cloths used to absorb

the menstrual discharge; there are no further details on their fabrication. And, even though Emily French worked as a nurse and midwife, she made no mention of any type of item she employed to absorb the lochial discharge.

From the review of literature, researchers in the subject of menstrual technology agree some type of item was used to absorb the menses, although information about menstrual management is difficult to locate. One scholar presents an opposing view. Shorter (1982) reported European "peasant" women menstruated directly onto their clothes before the twentieth century and, in some European countries, this practice "persisted until quite recently" (p. 261). If also a practice in the United States, this might explain the adamancy of Myra Fairbanks Eells and Sarah White Smith about the propriety of dark colored undergarments, as well as the absence of extra cloth for menstrual needs in their clothing lists. No evidence was located during this study to support Shorter's statement or to link this practice with menstrual management in the United States.

Summary

In the genteel atmosphere of the nineteenth century, menstruation, like pregnancy, was referred to indirectly, if at all. As a medical condition, menstruation was considered an appropriate topic of concern and study to Western doctors. However, the management of menstruation was seldom referred to

by orthodox physicians, sectarian healers, or midwives. Menstrual items in the Valentine Museum collection provide evidence of homemade menstrual technology during the nineteenth century, but afford no clue to the origin of the design. In the early twentieth century, products used for menstrual management were, perhaps, slowly beginning to be discussed in a more open and instructional manner, as suggested by Wood-Allen's instructions (1905).

CHAPTER 3

DATA COLLECTION AND PATENT ACTIVITY

Collection of Patents

After the review of literature, I focused on an examination of United States patents from 1790 through 1921 for information pertaining to menstrual technology. The year 1921 was chosen as a stopping point during the preliminary review of literature, because Delaney et al., (1976/1988), notable scholars on the topic of menstruation, marked 1921 as the year Kimberly-Clark marketed the first commercially successful sanitary napkin, Kotex®. It must be noted, however, that other researchers in this area, such as Bullough (1979) and Stanley (1993), disagree with Delaney et al. and contend that Kotex® was marketed publicly in 1920.

I discovered that using U.S. patents to research menstrual technology prior to 1920 had been performed on a limited basis. Bullough (1979) listed 18 menstrual product patents granted to men and women between 1854 and 1915 in his research on technological innovations (p. 245). Macdonald (1992) fleetingly referred to patents granted to women for menstrual items, listing three in an appendix. Stanley (1993) located 10 previously undiscovered patents for menstrual products granted to women between 1883 and 1894; I later learned that one of those patents was for a male suspensory bandage and truss. Busch (in press) also mentioned patents,

but listed only one. Counting Bullough's 18, Macdonald's 3, Stanley's 9, and Busch's 1, at least 31 patents for menstrual products were granted from 1854 to 1915. I then searched for overlooked patents.

Starting a review of patents from 1790, the year the U.S. Patent Office was created, I discovered no patents for any menstrual devices had been granted until 1854. On August 22, 1854, U.S. Patent No. 11,574 was granted to Alfred A. Starr for his "Catamenial Supporter" or "Catamenial Ameliator". The continuing search through 1921 revealed that 185 menstrual patents were granted (as well as three reissues). Appendix B is a chronological listing of the patents I collected in this study.

Patenting Activity by Sex of Patentee

Each of the 185 patents issued for menstrual technology was categorized by the sex of the patentee(s), presented in Table 3.1. For this table, the patent was categorized by the sex of the first person listed on the patent. For example, a patent granted to a man/woman inventor duo was placed in the "men" category; a patent granted to a woman/man inventor duo was placed in the "women" category. This type of categorization did not give me the real numbers of men and women involved in patenting menstrual products, however.

Table 3.1: Patent Activity by Sex of Patentee

	n	Percent
Men		
Individual	106	57.3%
Two-man team	8	4.3%
Man/woman team	2	1.1%
Women		
Individual	62	33.5%
Two-woman team	2	1.1%
Woman/man team	1	.5%
Sex unknown	4	2.2%
N = 185		

There were a number of paired inventor teams, as well as a number of "repeat patentees" that were listed as the inventors of individual patents. In order to count the actual numbers of men and women that were involved in patenting activity, I adjusted the numbers for paired inventor teams and repeat patentees. The adjustments, as well as a list of repeat patentees, may be found in Appendix C.

The 185 patents issued for menstrual technology during the years 1854 to 1921 involved 171 men and women, presented in Table 3.2. Included in the total number of persons involved in patenting menstrual technology are four inventors classified as "sex unknown." These patentees used initials instead of first names (N. Jensen, 1858, U.S. Patent No.

22,293; H.W. Libbey, M.D., 1868, U.S. Patent No. 75,434; G.C. Stillson, 1871, U.S. Patent No. 116,882), or had a first name that could not be confirmed as either male or female (Madison Vedder, 1862, U.S. Patent No. 35,338). As displayed in Table 3.2, more men than women were granted patents for menstrual products from 1854 through 1921.

Table 3.2: Actual Number of Men and Women Involved in Patenting Menstrual Technology, 1854-1899 and 1900-1921

	1854-1899		1900-1921		Combined	
	n	%	n	%	n	%
Men	40	59.7%	61	58.7%	101	59.1%
Women	23	34.3%	43	41.3%	66	38.6%
Sex Unknown	4	6.0%	0	0.0%	4	2.3%
Totals	67		104		171	

Although a summary of the data confirmed menstrual technology was dominated by men, the percentage of women involved in patenting menstrual technology is high enough to deserve further discussion. MacDonald (1992) and Stanley (1993) suggested certain technological inventions may be more

likely to be designed and patented by the sex that would most directly benefit from an improvement of that product. If true, the number of female patentees for items such as menstrual products might be discovered to be atypically high. Stanley (1993) attempted to examine this by posing the question "Did 19th-century women patent menstrual aids in disproportionate numbers; that is, more frequently than their percentage of all patents granted?" (p. 311).

Using her own "preliminary search" of patents issued to women for menstrual products between 1883 and 1894, she arrived at a total of 17 patents granted to women, then added the 12 patents granted to men discovered by Bullough (1979), for a total of 29 patents. Using these numbers, she calculated that 58% of all menstrual patents were granted to women during the nineteenth century (Stanley, 1993, p. 312). However, Stanley did not use a data set as complete as the one collected for this study. From my data, I calculated that 34.3% of all menstrual patents granted in the nineteenth century were granted to women. When her calculation is compared to mine, it would appear that her estimate was a bit optimistic.

Yet, her supposition was still supported. The total number of women who have been granted patents (in all product classes) in the United States has remained very low. In the nineteenth century, approximately 1% of all patents were

granted to women (Stanley, 1993, p. xxxvii). I found that 34.3% of nineteenth century menstrual patents were granted to women. At least in nineteenth century menstrual technology, it appeared that women inventors were granted patents in "disproportionate numbers; that is, more frequently than their percentage of all patents granted" (p. 311). Since my data stopped at 1921, I made no comparison between my findings and the overall percentage of women patentees in the twentieth century, estimated by Stanley to be 2% (1993, p. xxxvii).

Patent Activity by Residency and Region of Patentee

I then categorized the patentees by residency. Neither residency nor citizenship in the United States was a requirement for patenting inventions through the U.S. Patent Office. Table 3.3 shows that the majority of patents for menstrual products were granted to U.S. citizens, residing in the United States. Patents were also granted to resident aliens; seven patents were granted to non-resident aliens. I examined these patents to discover if the same patent had also been filed in the patentee's native country. Hannah Ferguson of Fort Erie, Canada, was granted U.S. Patent No. 474,378, on May 10, 1892, as well as having "obtained Letters Patent [sic] in Canada, dated March 20, 1890, No. 33,968". Emma J. Pike, of London, England, patented her "Suspensory Belt" under British patent No. 2,867, on February 17, 1891, as well as under U.S. Patent No. 529,750 in 1894. None of the other five

Table 3.3: Patent Activity by Residency of Patentee

N = 185	
<hr/>	
Patents granted to United States residents:	178
Includes U. S. citizens, as well as 5 citizens of other countries (Russia, Hungary, Great Britain, Japan, and Italy) that retained their foreign citizenship but resided in the United States	
Patents granted to non-resident, non-citizens:	7
Includes 3 patents issued to citizens of Great Britain, 2 patents issued to citizens of Canada, 1 patent issued to a citizen of Germany, and 1 patent issued to a citizen of Switzerland	

alien patentees noted in their patent letters whether their inventions had been patented in their home countries.

A further breakdown was made in Table 3.4, sorting the patents into regional divisions. Regional divisions are those set forth by the United States Bureau of Census (Bradshaw, 1988). Appendix D provides a listing of the states that are included in those regions.

Table 3.4: Patent Activity--Regions

		Men	Women	Unknown
Northeast	83	50.5	30.5	2
New York	45	26.5	17.5	1
Pennsylvania	12	6.0	6.0	0
Massachusetts	10	8.0	2.0	0
New Jersey	6	5.0	1.0	0
Rhode Island	4	1.0	1.0	0
Maine	3	2.0	1.0	0
Connecticut	2	0.0	1.0	1
Vermont	1	0.0	1.0	0
Midwest	63	41.5	20.5	1
Iowa	20	20.0	0.0	0
Ohio	13	7.0	5.0	1
Illinois	12	6.0	6.0	0
Indiana	5	2.0	2.0	0
Minnesota	4	0.0	4.0	0
Missouri	4	2.5	1.5	0
Michigan	2	1.0	1.0	0
Kansas	2	1.0	1.0	0
South Dakota	1	1.0	0.0	0
Wisconsin	1	1.0	0.0	0
South	21	11.5	8.5	1
Maryland	4	2.5	1.5	0
Washington D.C.	4	1.0	2.0	1
Tennessee	3	2.0	1.0	0
Texas	3	1.0	2.0	0
West Virginia	2	2.0	0.0	0
Kentucky	2	2.0	0.0	0
Florida	2	1.0	1.0	0
Alabama	1	0.0	1.0	0
West	11	8.0	3.0	0
California	6	4.0	2.0	0
Colorado	2	2.0	0.0	0
Washington	1	0.0	1.0	0
Montana	1	1.0	0.0	0
Arizona	1	1.0	0.0	0

(Table 3.4, continued)

		Men	Women	Unknown
Europe and Canada	7	4.0	3.0	0
Great Britain	3	2.0	1.0	0
Germany	1	1.0	0.0	0
Switzerland	1	0.0	1.0	0
Canada	2	1.0	1.0	0
Total	N = 185	115.5	65.5	4

Note: ".5" was used when a paired inventor team consisted of a man/woman or a woman/man; the "1" patent was divided equally between the two inventors.

The region with the greatest patent activity from 1854 through 1921 was the Northeast, followed by the Midwest, the South, and the West. The greater population of the Northeast and the number of medical centers and schools in states such as New York, Pennsylvania, and Massachusetts may have been instrumental in the early development of menstrual products. Subsidiary businesses and technologies, such as pharmaceutical and medical supply companies would also tend to be concentrated in or near medical hubs; these providers may have realized the commercial potential of menstrual products and have encouraged this burgeoning industry. Further examination revealed the majority of patentees listed urban areas, such as New York City, Boston, and Philadelphia, as their residence.

These addresses coincide with the established medical centers of the era (Starr, 1982).

Another explanation for greater patent activity in the Northeast may be related to the rise of interest in personal health. Social historians Morantz (1977) and Verbrugge (1979) have documented the intensified concern about personal health and hygiene during the nineteenth century. This movement's foremost advocates were predominantly Euro-American, middle to upper class urban women, who through such organizations as the Ladies' Physiological Institute of Boston and Vicinity (Verbrugge, 1979) and the Women's Christian Temperance Union (Blocker, 1989; Willard, 1883) attempted to educate women in basic health issues through classes and lectures.

The Midwest was the second most active region in registering patents for menstrual technology. Although Iowa led the Midwestern states in number of patents granted, this number must be cautiously interpreted. All twenty of the Iowa patents were granted to one man, Willard Green, on one day, January 16, 1906. Listing his address as Muscatine, Iowa, Green, who assigned all patents to The Absorbent Fiber Company of Portland, Maine, apparently patented any and every modification he made to his "Absorptive Bandage." For sheer numbers, only the group of patentees residing in New York City beats Green of Muscatine. Midwest patentees of menstrual

products, like those in the Northeast, tended to reside in urban areas, such as Chicago.

I also plotted the spread of patenting activity, by area and year. Starting from the metropolitan areas of New York, Washington, D.C., and Boston, the patents dispersed westward through the contiguous United States. The westward movement of patent activity corresponded roughly to westward settlement, as well as to admission into statehood, particularly in the Midwest and West. Although patenting activity was concentrated in the Northeast, menstrual products were being developed in all parts of the country.

Summary

In this investigation, 185 patents granted for menstrual technology from 1854 through 1921 were discovered. There were 171 people involved in patenting menstrual products: 101 men, 66 women, and 4 persons of unknown sex. Although more men than women were granted patents for menstrual products, the total percentage of women patentees of menstrual products is atypically high.

Patents granted in the United States were issued to U.S. citizens residing in the U.S., non-citizen residents, and citizens of European nations and Canada. The largest number of patents were issued to U.S. citizens who were living in the Northeast, followed by the Midwest, the South, and the West. In regional divisions, residents of urban areas, such as New

York City, Boston, Philadelphia, and Chicago, represented the majority of patentees of menstrual technology.

CHAPTER 4**DESIGN AND MATERIALS IN MENSTRUAL TECHNOLOGY**

An overwhelming diversity and complexity of types of menstrual products were described in the patent letter texts and depicted in the product illustrations. Upon closer examination, menstrual technology patented from 1854 through 1921 can be divided into six categories. The major categories consisted of (1) **belts or supporters**, from which were suspended (2) a **catamenial sack, pouch, shield, menstrual receiver, or napkin-holder**, into which was placed (3) an **absorbent**, consisting of cloths, pads, napkins, sponges, or raw waste fibers. Ancillary categories of menstrual patents were (4) **attaching devices** used to secure and connect the catamenial sack to the supporter, (5) **catamenial garments or appliances** that aided in protecting the wearer's clothing, and (6) **vaginally inserted menstrual retentive cups**.

Of the six categories, the largest number of patented menstrual products were for supporters, catamenial sacks, and absorbents, either as a single product or as a combination product. In most instances, the menstrual product patented was labeled as a "Catamenial Sack" regardless of product function, although menstrual products were called by a variety of names. Appendix E is a listing of the names given by the patentees to their products.

Belts and Supporters

The purpose of the belt or supporter was to hold the catamenial sack or napkin close and snug to the body, preventing the catamenial discharge from escape. The development of a more satisfactory menstrual supporter was the focus of the first menstrual product patent discovered in this study. According to Alfred A. Starr (1854)

The method usually adopted by females to secure themselves from inconvenience during their menstrual periods is to girdle themselves with a tape or string to which the ends of the napkin used to cover the vulva are attached (U.S.P. No. 11,574)

He improved on this "method" by patenting a "double-acting spring intended to girdle the waist of the female." Using four light elastic steel-springs, he created a belt to which the ends of a "napkin" or menstrual cloth could be fastened (Figure 4.1). Realizing bare steel might be uncomfortable next to the skin, he suggested the steel be "bound round with a covering of fine leather or other suitable material." Although steel and leather were used in the very early patented supporters, in the 1860s catamenial supporters were generally constructed out of non-coated fabrics. The most popular closures used were metal buckles, and buttons and buttonholes; these fasteners also allowed a moderate degree of adjustability.

Another significant change in the menstrual belt or supporter was the utilization of elastic material in

construction. The use of "elastic bands" was mentioned in the second menstrual patent found, U.S. Patent No. 22,293, patented December 14, 1858, by N. Jensen. During the 1850s, however, the meaning of the word "elastic" did not necessarily denote the presence of an elastomeric fiber. Ewing (1978) discovered that in England during the 1850s, the word "elastic" was often used to describe woven fabrics; whether this meaning was used in the United States during this time is unknown. The illustration and the patent letter text for U.S. Patent No. 22,293 provided no clarification of the fabrication of the "elastic" bands (Figure 4.2). By 1864, however, from the illustration of Robertson's "Catamenial Bandage" as well as his accompanying text (U.S.P. No. 45,523), the term "elastic" appeared to refer to a webbing or narrow textile partially composed of rubber to give it elasticity (Figure 4.3). After 1864, elastic was routinely mentioned as a material used in menstrual supporters, particularly as part of the straps that hung from the menstrual belt and attached to the catamenial sack. Seldom was elastic used for the entire menstrual belt or supporter and was utilized more frequently in inserts that contributed to the adjustability of the product.

Overall, inventors of menstrual technology were less concerned with developing specific materials to be used for the supporter. Supporter materials listed in patent texts

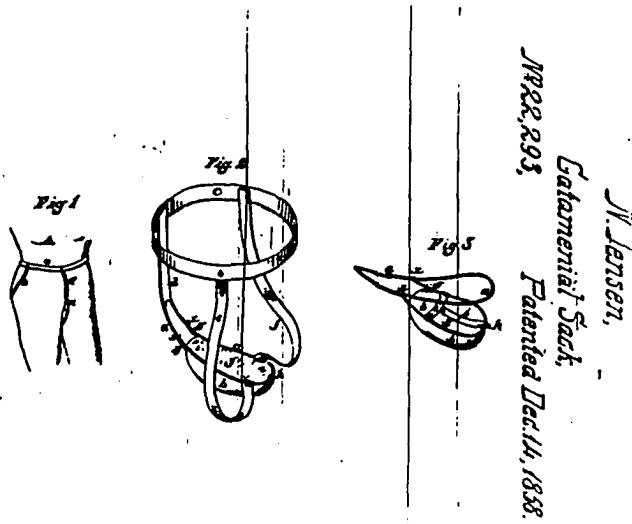

Figure 4.2. "Catamenial Sack," patented by N. Jensen, December 14, 1858, U.S.P. No. 22,293.

*D.F. Robertson,
Catamenial Bandage,
No. 45,523, Patented Dec. 20, 1864.*

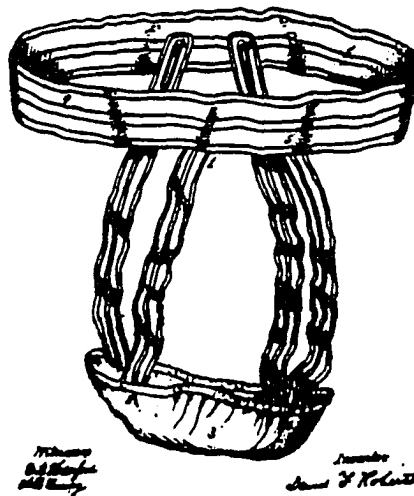

Figure 4.3. "Catamenial Bandage" patented by David F. Robertson on December 20, 1864, U.S.P. No. 45,523.

often are grouped together under the general phrases "any pliable material" and "any suitable material." Perhaps the techniques and materials available for menstrual products were limited in performance; therefore, inventors concentrated on improving menstrual supporter design, which may have afforded greater potential for a successful product.

The position of the menstrual supporter when worn was also a concern of patentees. Sketches that accompany early patents for menstrual supporters displayed that the belt was to be worn at the waist. By 1867 (Belvin, U.S.P. No. 68,688) the position moved to just below the waist, allowing for "the whole weight of the truss" to bear directly on the hips, "thereby relieving, in a considerable degree, the female of the pain experienced by her during the critical period." Belts moved back up to the waist area immediately after 1867, and, from 1868 through 1921, vacillated between the waist area and the hip area.

The inconsistency of the positioning of the menstrual supporter may be related to health beliefs, as well as fashion trends. Gynecology, a new medical specialty of the nineteenth century, focused on the female reproductive system. The public believed the reproductive system was to be protected and supported, with no undue strain placed on the lower abdominal regions. From a review of the patent letters, I found that the menstrual supporter not only held up the

catamenial sack, but also played a therapeutic role, providing support, protection, and a redistribution of pressure on the womb, essential during the woman's "critical period" (Belvin, 1867, U.S.P. No. 68,688).

Patents showed specifics of the position of the menstrual supporter. Patents often included drawings of the menstrual supporter as it should be worn on the body. There were various types of sketches used, ranging from detailed full front and back body sketches to minimalistic sketches of the body or sections of the body. The menstrual supporter and attaching products were often depicted being worn next to the body, underneath all of the outer and undergarments. Patent drawings illustrating the position of the menstrual product on the person may have been instructional sketches. Perhaps the product was considered so original by the inventor a drawing was necessary to show the people at the Patent Office how the product was intended to be worn. Drawings of menstrual products on the body appeared to have been used when the product was complicated or there might have been confusion as to where the individual parts of the items should be placed on the body.

The fashionable cut of corseting also affected the position of the menstrual product. As the nineteenth century progressed into the twentieth century and the hoop skirt disappeared, the desired silhouette required slender hips as

well as a small waist. Corsets became longer, ending several inches below the waist, as well as having a center front dip. Because of the length of the corset, the positioning of the menstrual supporter needed to be adjusted. Although the longer corsets were adopted earlier and menstrual supporters were illustrated being worn below the waist, problems caused by the position of the corset are not mentioned in the patent letters until 1896. Ballard's 1896 patent letter stated her "appliance" was to be worn low on the hips, and "can be put on and taken off without opening the corset" (U.S.P. No. 570,216). After 1900, the menstrual supporter was usually positioned just below the waist, and worn over the corset, according to menstrual product patent sketches from 1900 through 1914 (Figure 4.4). Wearing the menstrual supporter over the corset was probably more comfortable; since the corsets were tight-fitting, the pressure on the menstrual supporter from the corset would no doubt be painful. Changing the menstrual absorbent or carrier would also be easier if the supporter were worn outside the corset.

Although most menstrual supporters patented during this time were to be worn at or near the waist and hip areas, suspender menstrual supporters were also patented (Figure 4.5). Three patents for suspender catamenial supporters were located during the analysis of patents (Ellis, 1875, U.S.P. No. 169,245; Willoughby, 1891, U.S.P. No. 463,819; Kirwin,

951,184. M. M. GILLAM. CATAMENIAL BANDAGE. APPLICATION FILED MAR. 10, 1906. Patented Mar. 8, 1910. SIXTEEN—SEVENTY 1.

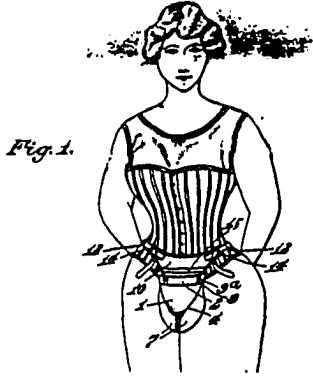

U.S.P. No. 951,184
March 8, 1910
Manly M. Gillam

979,730. CATAMENIAL BANDAGE. APPLICATION FILED MAR. 10, 1910. Patented Dec. 27, 1910.

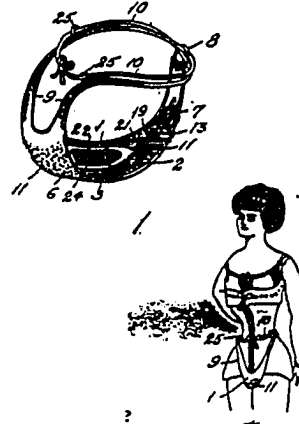

U.S.P. No. 979,730
December 27, 1910
Ida M. Argo

1,064,836. A. I. JORDAN. CATAMENIAL DEVICE. APPLICATION FILED MAR. 10, 1906. Patented June 17, 1913.

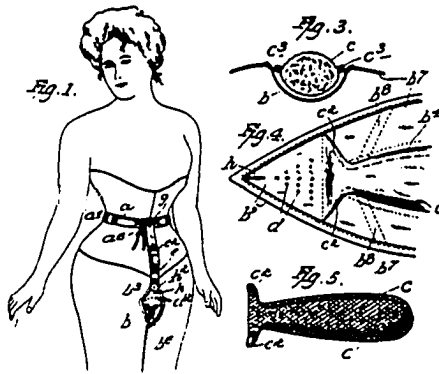

U.S.P. No. 1,064,836
June 17, 1913
Abraham I. Jordan

Figure 4.4. Three patent drawings that illustrate the position of the menstrual supporter during use.

S. K. ELLIS.
Suspenders.

No. 169,245

Patented Oct. 26, 1875.

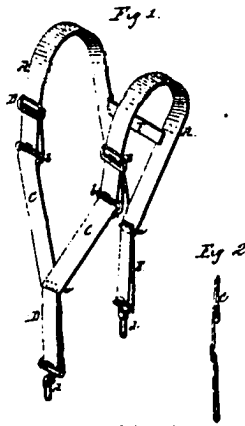

U.S.P. No. 169,245
October 26, 1875
Stephen K. Ellis

L. WILLOUGHBY.
GYNÆCEAL AND MENSTRUAL SUPPORTER.
No. 463,819. Patented Nov. 24, 1891.

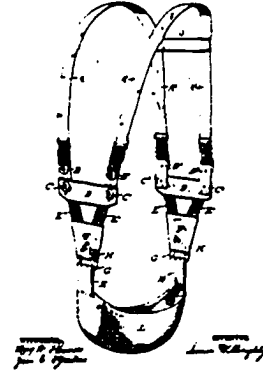

U.S.P. No. 463,819
November 1891
Annie Willoughby

(No Model.)

E. KIRWIN.
CATAMENIAL BAG.

No. 514,717.

Patented Feb. 13, 1894.

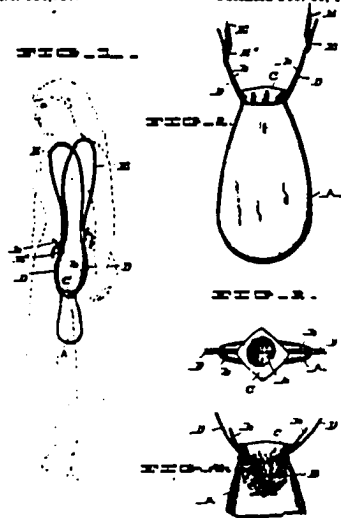

U.S.P. No. 514,717
February 13, 1894
Eliza Kirwin

Figure 4.5. Three suspender menstrual supporters.

1894, U.S.P. No. 514,717). As will be presented in Chapter 5, advertisements for suspender menstrual products appeared in the 1870s.

Catamenial Sacks

Although the supporter was the first menstrual product patented, developing and improving the catamenial sack was the main direction of early menstrual technology research and development. Also called a pouch or receiver (and later, a napkin-holder), the catamenial sack was the component of the menstrual product that held the absorbent and contained the menstrual discharge, effectively preventing leakage. Because of its functions, the sack needed to be made from a waterproof "impervious material," such as oilsilk (or oiled silk) or india rubber.

A silk fabric soaked in oil to make the fabric waterproof, oilsilk was commonly used in rainwear or as a lining (Yarwood, 1986). Oilsilk was evidently a soft fabric; Gamage (1868) in U.S. Patent No. 84,874, stated that the "nature of the oiled silk renders the pad soft, flexible, and agreeable to the touch". Oilsilk could be kept clean by rinsing-off with water. References to the use of oilsilk as a component in menstrual products end in 1911.

The most popular "impervious material" used in nineteenth and early twentieth century menstrual products was vulcanized rubber, declared by an historian of the era as an invention

that belonged to the nineteenth century (Byrn, 1900). Rubber was first marketed in the United States in the 1820s, but enjoyed little commercial use because of undesirable physical changes during temperature fluctuations. The process of vulcanization, perfected and patented by Charles Goodyear in 1849, revolutionized the commercial possibilities of rubber. One of the most significant uses of vulcanized rubber was for the creation of "cloth impervious to water" (Byrn, 1900, p. 220). Inventors of menstrual products were quick to capitalize on this new technology. India rubber and rubber cloth appeared in menstrual products by 1858, in the second menstrual device, U.S. Patent No. 22,293; Jensen (1858) recommended the bag be constructed of "oilsilk, india rubber or other material impervious to fluids." From 1858 to 1921, other forms of vulcanized rubber were also used, with such names as vulcanized caoutchouc, gutta percha, elastic rubber, sheet rubber, dental rubber, velvet rubber, and pararubber. When worn next to the body, vulcanized rubber was recommended to be lined with a woven textile fabric of cotton, flax (linen), or silk fibers, in order to add comfort.

From 1854 through 1899, the predominant design of catamenial sacks was trough- or canoe-shaped (Figure 4.6). A separate absorbent, most usually a sponge or raw cotton fibers, was placed into the trough. The trough was designed to fit snugly against the vagina and hang down between the

G.E. Brinckerhoff,
Catamenial Sack,
No. 84,083, Patented Nov. 17, 1868.

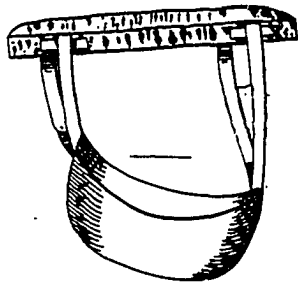

U.S.P. No. 84,083
November 17, 1868
George E. Brinckerhoff

W. A. DINSMORE
Catamenial Sack
No. 105,785. Patented July 26, 1870

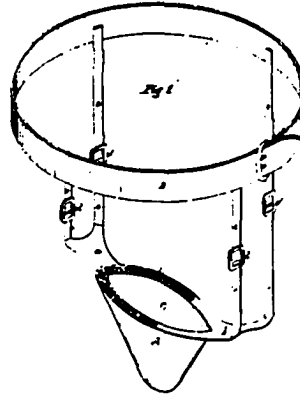

U.S.P. No. 105,785
July 26, 1870
Warren A. Dinsmore

(Model.)
H. F. FERGUSON.
CATAMENIAL SACK.
No. 474,378. Patented May 10, 1892.

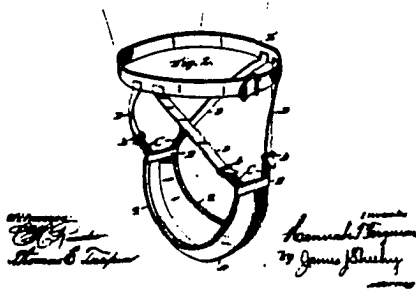

U.S.P. No. 474,378
May 10, 1892
Hannah F. Ferguson

No Model.
E. PARKER.
CATAMENIAL SACK.
No. 595,861 Patented Dec. 21, 1897.

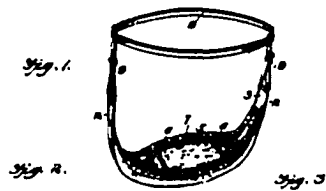

U.S.P. No. 595,861
December 21, 1897
Elizabeth Parker

Figure 4.6. Examples of trough- or canoe-shaped menstrual receivers.

thighs of the wearer. Usually, a stiff material was used for the catamenial sack itself. Hard rubber, celluloid, and wire frames were the types of materials used to create a stiff sack. Wire frames were typically used as support for other materials. Celluloid had limited use in menstrual products, and only appeared in two of the patents, U.S. Patent No. 794,181 (Hudson, 1905) and U.S. Patent No. 1,329,195 (Martinka, 1920). The most common material used for maintaining a stiff catamenial sack was hard vulcanized rubber. Molding the trough out of hard rubber would ensure that the sack would remain open. Hard rubber would also support a deep sack. A deep, trough-shaped catamenial sack was considered necessary to catch all the menstrual discharge.

At the time that the first catamenial sacks were being developed, doctors were debating how much menstrual blood was lost during each period. Today, researchers know that an average of 2 ounces of blood is lost during menstruation (Weideger, 1975); historically, that assessment was much higher. Dr. Joel Shew, of water-cure notoriety, addressed this issue in 1852, in a reassessment of the amount of menstrual blood lost during the average menstrual period. He reported that the ancient Grecian estimate of 20 pounds of blood lost had been gradually reduced, until by the mid-nineteenth century, the amount of blood lost during menstruation was considered to be 4 to 10 ounces, averaging

about 6 ounces (Shew, 1852, p. 47). Shew partially agreed with the estimate, but believed the amount of blood lost varied with the woman.

There was perhaps another reason why a catamenial sack of ample depth was considered necessary in the nineteenth century. There were other genito-urinary discharges for which catamenial sacks and absorbents could be used. Vaginal and uterine infections, such as leukorrhea (called "the whites" or the "white flowers"), *Trichomonas vaginalis* ("trich"), *candida albicans* (yeast infection), syphilis, and gonorrhoea were characterized by vaginal discharges; usually accompanied by an unpleasant odor (Shorter, 1982). Genito-urinary infections were usually untreated, because therapies that would cure these infections had not been discovered.

Damage during childbirth was also a cause of two particularly dread afflictions, vesicovaginal fistulas and rectovaginal fistulas (Shorter, 1982). A vesicovaginal fistula occurred when the tissue between the bladder and the vagina ripped, resulting in continual incontinence of urine. A rectovaginal fistula occurred when the tissue between the rectum and the vagina tore, and resulted in fecal excretion through the birth canal. Of the two fistulas, the vesicovaginal fistula was the most common. Although Dr. James Marion Sims had developed an operation in the mid-1800s that could repair the vesicovaginal fistula, women still suffered

the pain as well as the embarrassment caused by fistulas throughout the nineteenth century. Because some catamenial sacks were also designed to be used to collect "other discharges," they would have been a type of treatment or therapy for these afflictions, particularly for those women who had no access to gynecological surgeons.

"Other discharges" also referred to the lochia, the discharge occurring for four to six weeks after childbirth or miscarriage. The lochial discharge is heavier than the usual menstrual discharge and extra absorptive protection is necessary. A deeper catamenial sack, although primarily for menstruation, would also serve for containing lochial discharge without having to develop or fabricate a separate product.

Other catamenial sacks of unusual design were patented to fulfill the need, real or perceived, for a menstrual product that would have a considerable capacity for retaining liquids. Menstrual receivers in the shape of funnels were patented (Figure 4.7). In the United States patents that I studied, the first hard rubber funnel-shaped catamenial sack was not patented until 1878 (Schilling, U.S.P. No. 205,912). However, such devices were in existence at least as early as 1859, as established by Charles E. Clark:

G. SCHILLING.
Catamenial Saok.

No. 205,912. Patented July 9, 1878.

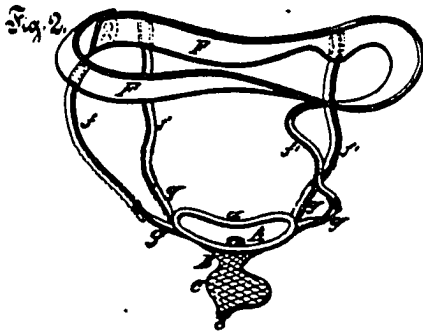

U.S.P. No. 205,912
July 9, 1878
Gustav Schilling

J. SHTUCHKA.
CATAMENIAL SACK.
APPLICATION FILED OCT. 16, 1906.

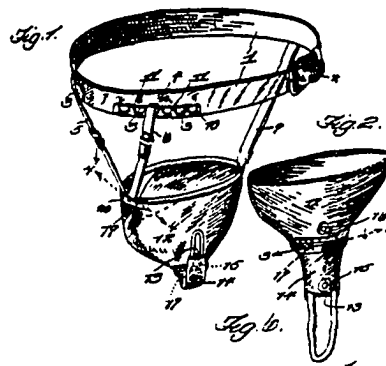

U.S.P. No. 844,198
February 12, 1907
Jacob J. Shtuchka

P. J. SCHELLER & N. I. HAAS
CATAMENIAL RECEPTACLE.
APPLICATION FILED OCT. 6, 1909.

913,983.

Patented Mar. 2, 1900.

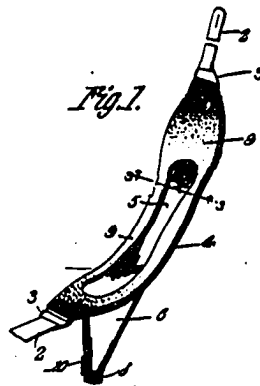

U.S.P. No. 913,983
March 2, 1909
Paul J. Scheller & Norman I. Haas

Figure 4.7. Funnel-shaped menstrual receivers.

I am also aware of the receivers of Stark and Segin, as described in "Fritz's **Bandagen und Maschinen**" pages 161 and 163. Stark's instrument is a funnel made of tin and provided with means of strapping it to a person, while Segin's is a funnel made of gum (1859, U.S.P. No. 23,059)

I could not locate **Bandagen und Maschinen**.

The usual menstrual funnel patented in the United States was constructed from a stiff material (usually rubber), and had a screw-cap on the smaller end that, when unscrewed, would allow the wearer to empty the contents of the funnel as necessary. The most appropriate materials used to build the funnel could be thoroughly cleansed between uses. There were only seven menstrual funnels patented, but these products continued to be developed as late as 1920.

Inventors also experimented with non-waterproof fabrics, such as muslin and flannel, and non-textile products, such as chamois and morocco leather, for use in catamenial sacks. Non-waterproof textile fabrics had the advantage of washability and sterilization after use. Non-textile products were chosen for softness; patentees recommended leather items be lined with a soft fabric, usually a woven silk. When comfort was more critical than containment of discharge, soft materials were considered more serviceable.

From 1900 through 1921, although trough-shaped receivers continued to be patented, the majority of patented menstrual receivers were flat (Figure 4.8). Flat receivers were fabricated out of materials softer and more pliable than the

No. 676,636
 D. P. SONNEHILL.
 CATAMENIAL BAG.
 Patented June 18, 1901.
 (No Model.)

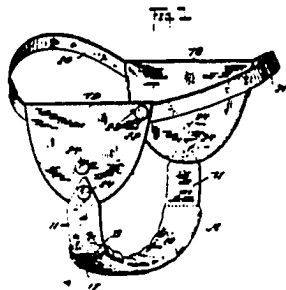

U.S.P. No. 676,636
 June 18, 1901
 Daisey P. Sonnehill

J. L. BORNSTEIN.
 SANITARY SCOOPER.
 APPLICATION FILED AUG. 17, 1911.
 1,041,420. Patented Oct. 15, 1912.

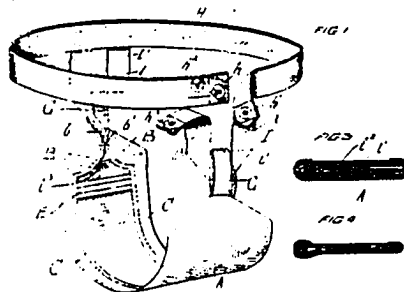

U.S.P. No. 1,041,420
 October 15, 1912
 Jennie L. Bornstein

C. H. RUTHERFORD.
 CUP-LIKE HOLDER.
 APPLICATION FILED AUG. 22, 1915.
 1,168,679. Patented Jan. 18, 1916.

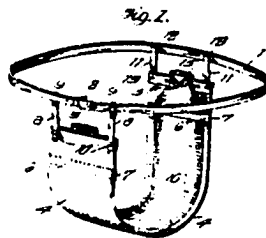

U.S.P. No. 1,168,679
 January 18, 1916
 Charles H. Rutherford

Figure 4.8. Examples of flat menstrual receivers or napkin-holders.

majority of those used for the trough-shaped receivers. As with supporters, the receivers were usually cleaned between uses. Although flat, most had a slight center depression or elastic straps across each end in order to hold the absorbent or the pad securely in the receiver. The prevailing shape for the flat menstrual receiver was the rectangle, although other shapes, such as ovals, panduriforms (violin-shaped) and triangles were patented. When a triangular shape was used, the placement of the wider end was inconsistent. The majority of triangular shaped receivers placed the wider end in the front of the product; the design of the menstrual product in combination with the supporter looked similar to the modern thong bikini bottom brief or dance belt (Figure 4.9). The panduriform shape, best represented in a 1909 patent (Treber & Simon, U.S.P. No. 909,349), allowed for fit between the thighs, and extra protection in the front and the rear of the product (Figure 4.10).

One of the menstrual innovations often claimed to have been discovered in the late twentieth century had its inception in the nineteenth century. Menstrual receivers with side lapels or wings are mentioned in patent letters as early as 1865 (Perry, U.S.P. No. 49,915, Figure 4.11). Approximately 13 of the patents I examined referred specifically to lapels or wings. Most of the wings were attached to the menstrual receiver and served the purpose of

No. 708,933

M. M. SPAULDING.
CATAMENIAL PAD.

(The Body)

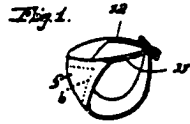

U.S.P. No. 708,933
September 9, 1902
Mattie M. Spaulding

No. 768,861.

J. L. MINGES.
CATAMENIAL PAD.
APPLICATION FILED APR. 16, 1904.

PATENTED AUG. 30, 1904

FIG. 1.

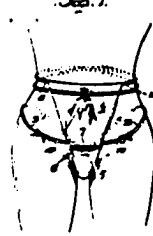

FIG. 2.



U.S.P. No. 768,861
August 30, 1904
John L. Minges

Figure 4.9. Triangular shaped menstrual receivers.

909,349.

J. A. TREBER & B. SIMON.
CATAMENIAL PAD.
APPLICATION FILED MAY 26, 1909.

Patented Jan. 12, 1909
TREBER-SIMON.

Fig. 1.

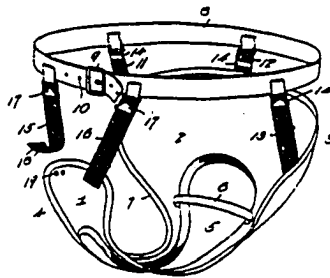

U.S.P. No. 909,349
January 12, 1909
John A. Treber & Bernhard Simon

Figure 4.10. Panduriform menstrual receiver.

Do. GRAMA. PATENTED SEPT. 12, 1865.
E. L. PERRY.
CATAMENIAL BAG.

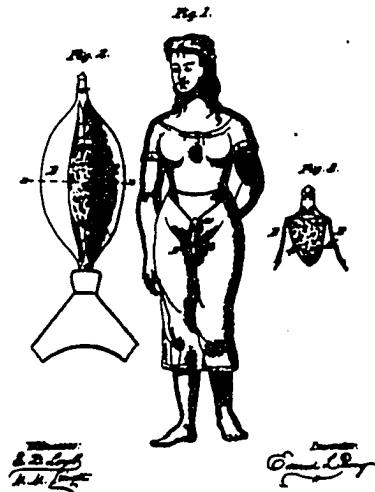

(Sections "B" are the wings.)

U.S.P. No. 49,915
September 12, 1865
Edward L. Perry

1,022,894. Patented Apr. 9, 1912.
E. SPRAGUE.
CATAMENIAL BAG.
APPLICATION FILED APR. 17, 1911.

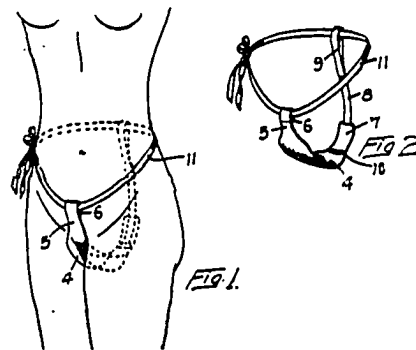

U.S.P. No. 1,022,894
April 9, 1912
Elizabeth Sprague

Figure 4.11. Examples of menstrual receivers with "wings."

protecting the wearer's clothing from leakage of the menstrual discharge by resting on the inner thighs of the wearer.

(Unlike today's pads with wings, these wings were not designed to wrap around the crotch section; as will be explained in Chapter 7, there were no crotch sections in most underdrawers at this time.)

Although only a small number of the patents specifically mention wings, many of the flat menstrual receivers would form wings at the sides during their use. The pressure of the thighs would naturally bend the sides of the menstrual product downward. If the product were wide enough, enough of the product would lie against the inside of the thighs, ready to absorb any discharge that might escape. This may have been an assumed performance characteristic of the flat menstrual product, especially receivers of excessive width.

Although oval, triangular, and panduriform shaped menstrual receivers were patented, the most frequently developed flat receiver was rectangular. This trend paralleled the development of menstrual pads or napkins for use in conjunction with menstrual receivers. As the receiver and the absorbent merged into one unit, the flat rectangular shape dominated.

Absorbents

Between 1854 and 1921, the term "absorbent" included materials such as sponges, cotton fibers, cotton waste, wood

wool, wadding, paper, wood fibers, and other fibrous material, as well as fabrics such as linen, Turkish toweling, bath toweling, canton flannel or any "suitable absorbent material." The most frequently mentioned absorbents were sponges and raw cotton, usually recommended in an "either-or" situation. The materials were endorsed for their low cost, as well as absorbency, and offered the menstruating woman a choice in the type of absorbent used. Both had advantages. Sponges could be rinsed and reused, emphasizing economy and reusability. Raw or waste cotton, on the other hand, could be thrown away or burnt, emphasizing convenience and cleanliness; the disposable feature of raw cotton also meant women would not have to rinse out the absorbent "should this operation be disagreeable" (Perry, 1865, U.S.P. No. 49,915). Although raw cotton appeared to be the most popular absorbent material, wood wool was also frequently used. Wood wool consisted of extremely fine shavings of pine wood (Farrell-Beck & Kidd, 1993), and was utilized in a number of industrial, as well as domestic, needs.

Disposability of menstrual absorbents is generally considered a twentieth century practice, with the assumption that prior to the twentieth century most women routinely washed and reused menstrual cloths. As documented by Emily French in her 1890 diary (French, 1987), this was a practice. In a review of the patent letters, reusability and washability

of menstrual products was also emphasized, possibly to facilitate the patenting process, and to encourage eventual consumer purchase. Upon a closer examination of the patents, I found that the notion of reusability was more strongly emphasized for the menstrual supporters and receivers than for the absorbents. The recommended use of raw or waste cotton as expendable absorbent material was mentioned early in the development of menstrual technology; therefore, the idea of a commercial disposable sanitary product had its roots in the nineteenth century.

Early disposable menstrual absorbents referred to in the patent text or illustrations did not feature a specific form, nor were these the primary focus of menstrual inventions from 1854 through 1874. My patent search confirmed Busch's findings (in press) that the first United States patent for a disposable menstrual pad was granted to Joseph Hatch in 1875, U.S. Patent No. 162,647. Of the patents collected, only 9 of the patent texts specifically mentioned disposability as a reason for invention. Upon closer analysis of the patent texts, I determined that 30 additional pads could also be considered disposable because of the materials used for the inner section of the pad, the covering fabrics, and the construction. In total, there were 39 patented disposable pads; Figure 4.12 presents some examples of disposable menstrual pads.

J. H. HATCH.
Ladies' Paper Towel.
No. 162,647. Patented April 27, 1875.

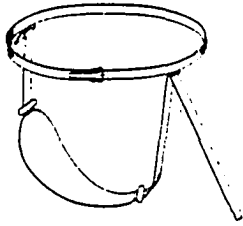

U.S.P. No. 162,647
April 27, 1875
Joseph H. Hatch

No. 235,884 Patented Dec. 28, 1880

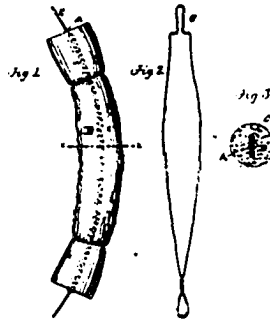

U.S.P. No. 235,884
December 28, 1880
John Korff

No. 811,704 PATENTED FEB. 6, 1906

C. S. DIX.
CATAMENIAL BANDAGE.
APPLICATED BY HIM NOV. 16, 1905.

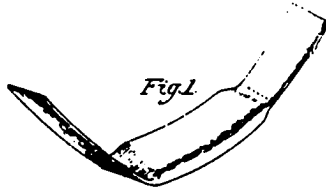

U.S.P. No. 811,704
February 6, 1906
Edward S. Dix

No. 860,111 PATENTED JULY 16, 1907

W. E. WRIGHT.
SANITARY PAD.
APPLICATED FROM MARCH 20, 1906.

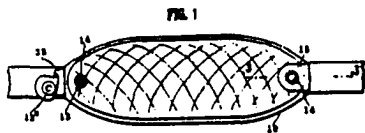

U.S.P. No. 860,111
July 16, 1907
William E. Wright

No. 903,895 PATENTED NOV. 17, 1908

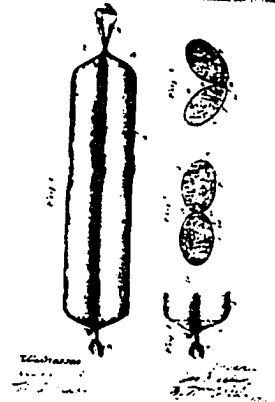

U.S.P. No. 903,895
November 17, 1908
Otto C. Schultz

Figure 4.12. Disposable menstrual pads.

Hatch used paper as his absorbent medium, but succeeding patents referred to other absorbent materials, such as excelsior; wood strands; "analogous granular material" such as sand; "vegetable fiber"; corn pith; wood wool; as well as unspecified "fibrous material." Appendix F is a listing of the patents, patentees, and the materials used in the disposable absorbent pads. To judge from the types of absorbents named in the patents, cellulosic fibers were the most frequently used absorbent material in pads. In most instances, the actual absorbent materials appeared to be existing waste products and not specifically invented for use in menstrual absorbents, unlike those in modern-day sanitary pads. In today's jargon, most menstrual absorbents were an early example of recycling.

Some patents for menstrual pads attempted to combine features of disposability and reusability. Such patents featured flat pieces of woven fabrics, usually made of cotton yarns, folded into rectangular napkins (Figure 4.13). In the folded inner sections, an absorbent material such as cotton waste fibers could be inserted. The flat fabric could be washed and reused, and the absorbent discarded after use. This may have been the predecessor of the "maxi" pad. When extra protection was needed, a thicker pad could be concocted; when the need was not so great, the flat fabric napkin could be used alone.

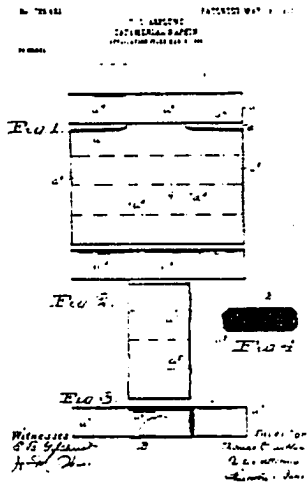

U.S.P. No. 728,432
 May 19, 1903
 Thomas C. Asplund

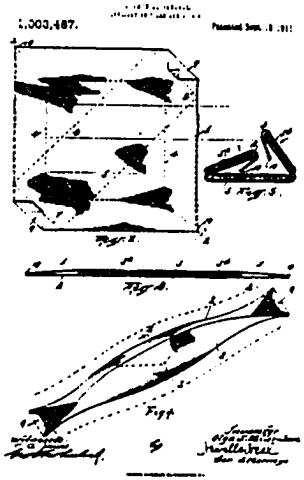

U.S.P. No. 1,003,487
 September 19, 1911
 Olga J. Miller-Jones

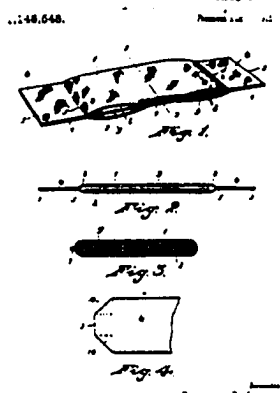

U.S.P. No. 1,148,548
 August 3, 1915
 G. B. Smith

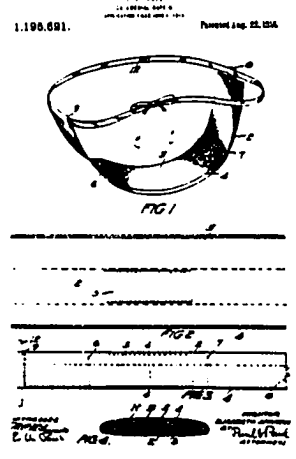

U.S.P. No. 1,195,621
 August 22, 1916
 Elizabeth Sprague

Figure 4.13. Menstrual receivers combining characteristics of disposability and reusability.

When reusability was desired, sponges were used as the absorbent in patents for menstrual products. Sponges referred to in early patents are most probably natural sponges, readily purchased at dry goods and drug stores, as well as mail order houses. By 1905, a new absorbent was being utilized in menstrual products. Mary Susan Merkley, in U.S. Patent No. 791,354, specified that her pad was "a block or slab of that material known in the trade as 'sponge rubber,'" a substance that "is particularly adapted for the use to which it is placed." Advocating the use of sponge rubber, Merkley wrote that unlike "ordinary sponge," sponge rubber does not have the "very fine interstices" or pores to trap "excrements," making thorough cleansing easier. Sponge rubber was also considered more pliable and softer, and would not harden during use, like natural sponges.

Overall, three trends in menstrual receivers and absorbents were identified from an examination of the patents. One trend was a move towards a flat catamenial sack or absorbent napkin, usually into a rectangular shape. The second trend was the merging of the catamenial sack or napkin-holder and the absorbent into one unit. The third trend was the creation of a totally disposable sanitary napkin.

These are subtle developments, however. The merging of the sack and absorbent into one unit did not monopolize menstrual pad development. Although combining the sack and

the absorbent into one unit would also reduce the bulk of the menstrual product, the continued use of two products had advantages: more protection against leakage by the napkin-holder. Patent texts implied that the ends of disposable absorbent pads were not very durable, exhibiting a tendency to tear away from the supporter or belt. Another problem was the inability of the napkin to maintain its shape during use. To provide comfort during use, a soft material was desirable for napkins; once saturated the napkin often lost its shape, and could become a thin, uncomfortable string, sagging away from the body. Because the napkin-holder was made of material that would maintain its shape, the holder provided support for the absorbent.

Other practical problems were associated with the development of the disposable sanitary napkin. One was the problem of disposal. Burning was one option for the disposal of used pads. Although sanitary towel cremators were available in Great Britain during the 1890s (Jalland, 1986), I did not find towel cremators in U.S. patents. By 1892, according to the patent letters, discarding the used pad by throwing it down the "closet" was suggested (Masser, 1892, U.S.P. No. 480,876). When each dwelling had a separate septic system and indoor commode or outhouse, the size of the pad would not be a problem for disposal down the water closet. But as sewer lines became a public utility, with intricate

pipeline connections, the pad had to collapse or disintegrate into pieces small enough to insure that the lines would not clog.

Perhaps to guard against sewer lines clogging, early disposable pads were only partially disposable and consisted of three parts: an inner absorbent material, a waterproof layer, and a cloth covering. When the pad was to be discarded, the waterproof layer and cloth covering would be pulled away from the inner absorbent, which could be disposed of down the water closet. The remaining two sections would have to be thrown away or burnt. (This method of disposal is identical to the disposal instructions recommended for late twentieth century disposable infant diapers.)

Attaching Devices

Most attaching devices were considered as part of the supporter or receiver patent, but some were patented individually. Not only important in securing the menstrual receiver to the supporter, they also affected the ease of removal and reapplication of the sack or absorbent. A variety of attaching devices was illustrated in the patents: metal two-pronged buckles, wire D-rings, buttons and buttonholes, elastic rubber loops, and the ball and socket fastener (now called a "snap"). In 1900, two inventors suggested using the corset as the supporter for the sack or napkin (Moberg & Brady, U.S.P. 660,388), and some patents illustrated the use

of small metal holders attached to the front and the rear of the lower edges of the corset (Cortland, 1901, U.S.P. No. 686,028; Schopbach, 1904, U.S.P. No. 749,453, Figure 4.14). Adapting the corset as a catamenial supporter would have reduced extra bulk produced by a separate supporter at the waist and hip, and would have eliminated the need to undo the corset to change the absorbent.

One of the most frequently adapted and used attaching devices for menstrual products was the safety pin (Figure 4.15). Although the Romans had developed and used a form of safety pin at least 2500 years ago, the safety pin was "rediscovered" in the nineteenth century (Petroski, 1992, p. 93). In 1842, Thomas Woodward of Brooklyn, New York, patented a "manner of constructing shielded pins for securing shawls, diapers, &c. [sic]" (p. 93). Woodward's "Victorian shielded shawl and diaper pin" had no integral pin or loop and relied on the bulk of the fabric to hold the pin in the shield. This limited the pin's usefulness and range of applications. Further improvements by Walter Hunt of New York City in 1849 produced the "dress pin," with a spring enabling the pin to stay fastened; in essence, a self-sprung pin (p. 94). It was this spring-loop or safety pin, similar if not identical to the modern-day pin, that was implemented in menstrual technology.

No. 686,028

A. CORTLAND.
CATAMENIAL SACK.
Application filed Dec. 6, 1901.

Patented Nov. 5, 1901

100 Model.

2 Sheets—Sheet 1

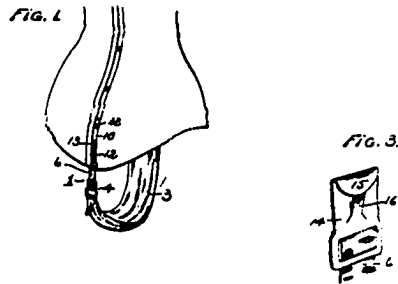

U.S.P. No. 686,028
November 5, 1901
Adelaide Cortland

No. 749,453.

C. H. SCHOPBACH.
ATTACHING DEVICE FOR SANITARY NAPKINS.
Application filed Sept. 26, 1904.

PATENTED JAN. 12, 1904.

NO MODEL.

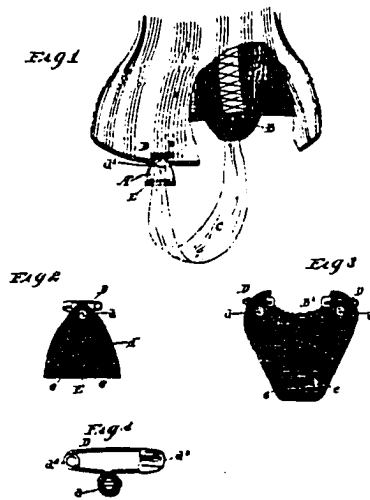

U.S.P. No. 749,453
January 12, 1904
Charles H. Schopbach

Figure 4.14. Attaching devices.

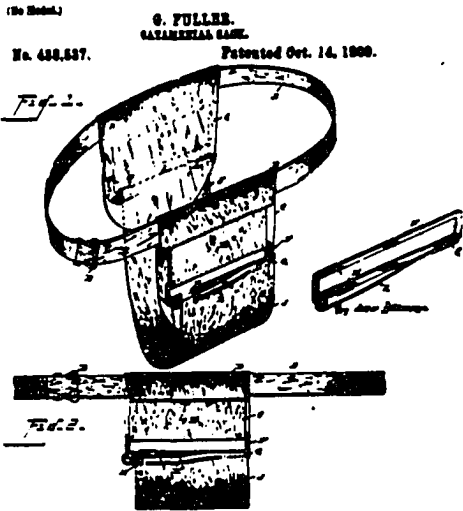

U.S.P. No. 438,537
 October 14, 1890
 Georgiana Fuller

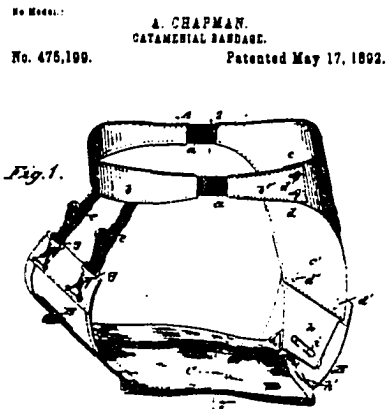

U.S.P. No. 475,199
 May 17, 1892
 Anna Chapman

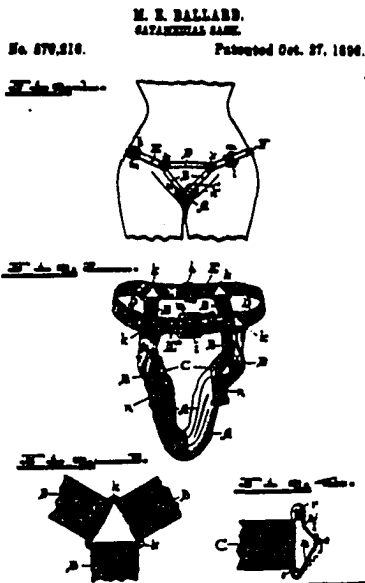

U.S.P. No. 570,216
 October 27, 1896
 Mary E. Ballard

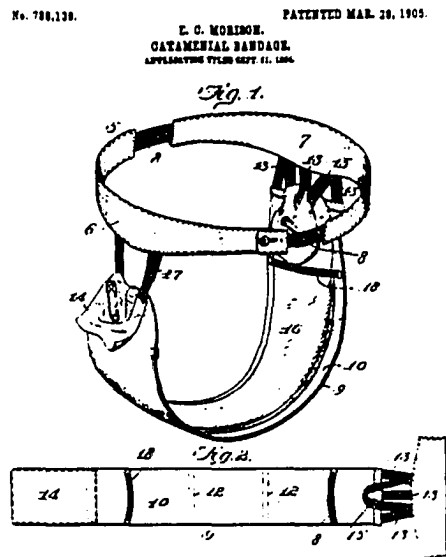

U.S.P. No. 786,136
 March 28, 1905
 Emma C. Morison

Figure 4.15. Safety-pins and modifications of safety-pins used in menstrual products.

Ellis mentioned a pin in his suspender supporter (1875, U.S.P. No. 169,245). From the patent illustration (see Figure 4.5) this pin does not appear to be a spring loop pin. The first written reference to spring-loop pins occurred in 1882 (Wasserman, U.S.P. 267,956). The function of the pin was to hold the absorbent pad securely to the catamenial sack. The next reference in a patent to the use of a spring loop-pin occurred in 1890 (Fuller, U.S.P. 438,537). In this patent, the spring loop-pin had been adapted to be used as the front connection between the supporter and the catamenial sack. The action of the pin would allow the "napkin" to "be easily removed from and attached to the belt."

The first time a modern safety pin was illustrated in a patent drawing can be seen in U.S. Patent No. 475,199 (Chapman, 1892). The name "safety pin" was also used by the patentee to describe this component of her "Catamenial Bandage." It served the purpose of securing the napkin or cloth to the catamenial sack.

Another modification of the basic safety pin occurred in 1896 (Ballard, U.S.P. 570,216, Figure 4.15). The safety pin featured a V-shaped bend in its length; this bend took in the thickness of the edges of the napkin "without binding, as would be the case were a straight pin used." Like U.S. Patent No. 438,537 (Fuller, 1890), this alteration was to make removal and reapplication easier. Another modification was

represented in U.S. Patent No. 749,453 (Schopbach, 1904, see Figure 4.14). For this "Attaching Device for Sanitary Napkins", the safety pins carry the stud members of stud-and-socket fasteners. The pin with the stud was on a tab, and the pin was used to fasten the tab to the corset. The napkin could then be connected to another attaching device on the tab.

Other patents that illustrated safety pins or modifications of safety pins in their menstrual items are listed in Appendix G.

Catamenial Garments and Appliances

An important function of menstrual products was to prevent leakage of the menstrual discharge. Aesthetically, ideal menstrual products would not create any bulges or protuberances to disturb the line of wearer's silhouette. Perhaps because supporters, sacks, and absorbents were not completely successful, other types of menstrual products were developed during this time. "Catamenial appliances" or "catamenial devices" were specifically developed to protect a woman's outer garments. Other items such as dress or garment supporters and protectors may also have been adapted in menstrual management; many of these may not have been patented as catamenial devices. From the patent search, I discovered only four devices developed solely to protect the outer garments from leakage or soiling; all patentees were female:

Scott, 1904, U.S.P. 778,077; Aiken, 1908, U.S.P. 899,196; Milkes, 1914, U.S.P. 1,108,206; Myers, 1914, U.S.P. 1,122,988. These appliances were similar in design, and were basically aprons suspended from the waist to cover the buttocks area of the wearer, and acted as a protective back shield (Figure 4.16). Most incorporated a napkin-holder in their design, as well as hose supporters (garters). Not only would the aprons protect against staining of the outer garments, but they also served to smooth the silhouette and eliminate any tell-tale bulges that may have resulted from the use of catamenial sacks and supporters. The aprons could also have been used when the wearer was not experiencing her menstrual period. The napkin-holder could, in some cases, "be removed from the apron, and the apron can then be worn under evening gowns and supper dresses," guaranteeing a smooth silhouette (Milkes, 1914, U.S.P. 1,108,206).

There were also attempts to design what might be considered a menstrual garment. These garments were designed to fit the front or back abdominal (lower torso) region or to completely encase the lower torso (Figure 4.17). When the garment enclosed the lower torso, there was a front drop section to allow for ease in changing the menstrual absorbent or pad; there was a back drop section to allow for "demands of nature" (Pfeil, 1913, U.S.P. No. 1,067,841). This type of catamenial garment appeared to have been modified from a pair

M. H. & I. R. HOSACK.
 NAPKIN OR SKIRT PROTECTOR.
 APPLICATION FILED AUG. 2, 1912

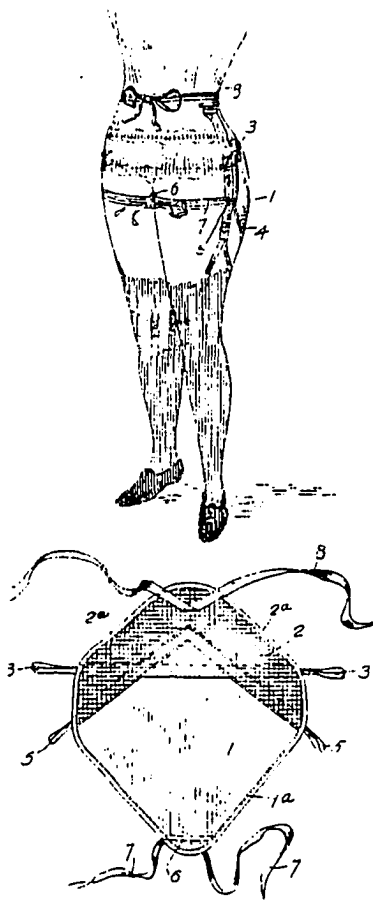

U.S.P. No. 1,058
 April 1, 1913
 Margaret H. Hosack
 Ida R. Hosack

L. G. MILKES.
 CATAMENIAL APPLIANCE.
 APPLICATION FILED MAR. 27, 1914.

1,108,206.

Patented Aug. 25, 1914.
 2 SHEETS-SHEET 1.

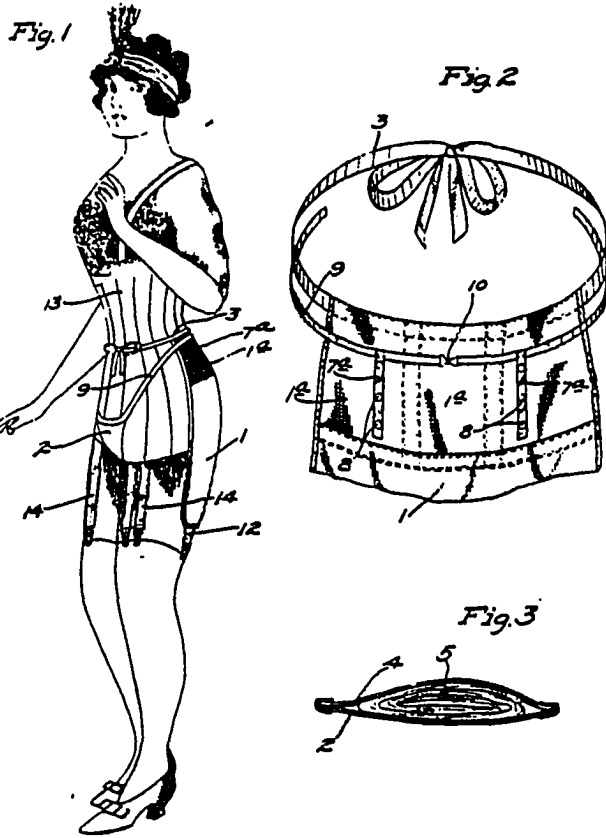

U.S.P. No. 1,108,206
 August 25, 1914
 Leah G. Milkes

Figure 4.16. Skirt protectors.

No. Model: E. A. WILEY.
CATAMENIAL SACK.
No. 395,411. Patented Jan. 1, 1889.

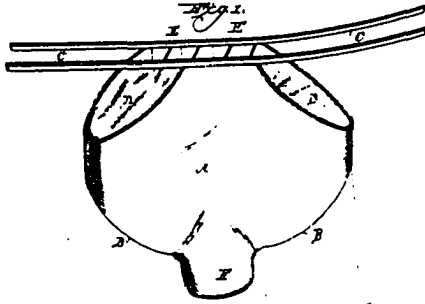

U.S.P. No. 395,411
January 1, 1889
Emma A. Wiley

No. 623,658. G. R. EVERSON.
CATAMENIAL GARMENT.
Patented Apr. 25, 1899.

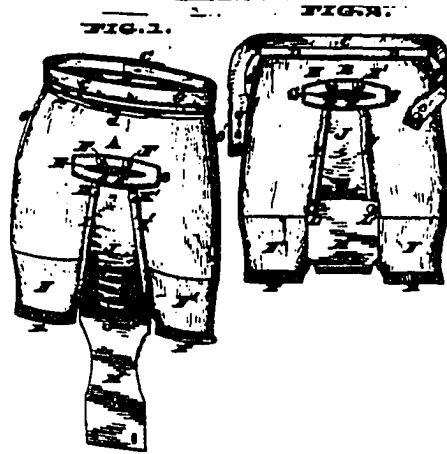

U.S.P. No. 623,658
April 25, 1899
George R. Everson

No. 833,849 S. G. SCHIFF.
CATAMENIAL GARMENT.
PATENTED OCT. 23, 1906.
APPLICATION FILED OCT. 17, 1906.

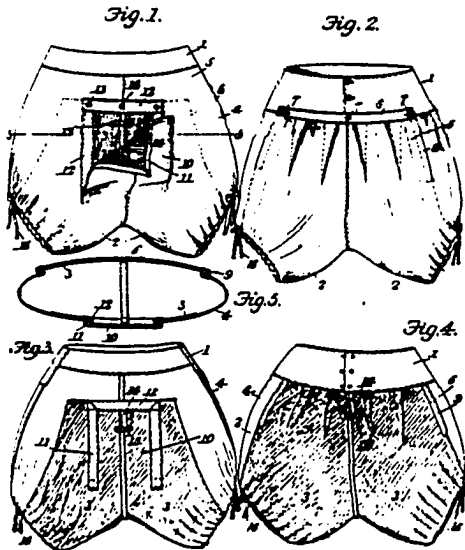

U.S.P. No. 833,849
October 23, 1906
Sarah G. Schiff

1,288,848. C. E. DUDLEY.
CATAMENIAL SACK.
APPLICATION FILED OCT. 1, 1917. Patented Dec. 24, 1918.

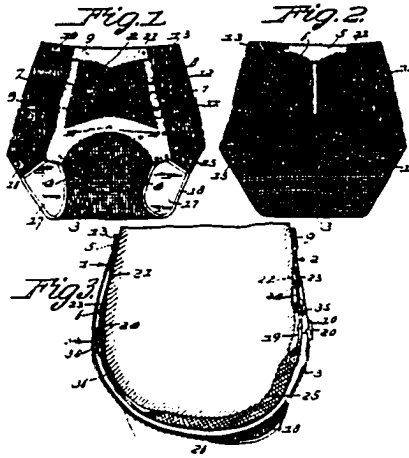

U.S.P. No. 1,288,848
December 24, 1918
Cora E. Dudley

Figure 4.17. Catamenial garments.

of drawers, with an extra crotch piece added, to support the menstrual pad or absorbent. By the twentieth century, the catamenial garment became more tailored, and looked more like full-length woman's panty underwear. Rubberized cloth was used in these garments to insure against leakage. Appendix H is a listing of enclosed or semi-enclosed catamenial garments.

Menstrual Retentive Cups (vaginally inserted)

Like catamenial appliances and garments, vaginally inserted menstrual retentive cups served to eliminate bulges under clothing and protect against leakage; because of their unique shape and positioning in the body, I considered them as a separate category of menstrual products.

The discovery of patents for vaginally inserted menstrual retentive cups during the nineteenth century is an exciting one, documenting that this form of menstrual protection was conceived of prior to the twentieth century. Researchers in menstrual technology generally consider the patenting of menstrual receiving cups as a mid-twentieth century development, citing the Tassette® rubber menstrual cup of the 1950s and the Tassaway® plastic menstrual cup of the 1960s and 1970s (Delaney et al., 1976/1988; Stanley, 1993). Vaginal inserts patented from 1854 to 1921 were cup-shaped, and were created from materials such as soft and hard rubber, as well as non-corrosive metals. Usually, a small sponge or other absorbent was also used inside the cup for extra absorbency.

These products were considered reusable, as well as easy to clean and sterilize.

The vaginally inserted menstrual retentive cup was perhaps inspired from other types of vaginal inserts. Since ancient times, vaginal inserts had been used by women and health practitioners for birth control, facilitating abortions, or as support for a prolapsed uterus or "fallen womb." Prolapse of the uterus could occur after an extremely difficult labor, and was a physically, as well as emotionally, crippling condition (Shorter, 1982). Until the twentieth century, there was no surgical remedy for this situation. As therapy for this condition, a device called a pessary could be used by women. Once inserted, the pessary would literally hold the uterus back inside the body. In most instances, pessaries were rings; by adding a cup or sack to a ring pessary, a device could be formed capable of catching the menstrual discharge. The adapted pessary served two purposes, support of the womb and containment of the catamenia; this dual function was mentioned in the patent texts. Other positive characteristics of menstrual retentive cups were the elimination of menstrual cloths and freedom from worry about leakage.

The first patent granted for a vaginally inserted menstrual retentive cup was to S. L. Hockert in 1867 (U.S.P. No. 70,843). This was a rubber sack that was attached to a

rubber ring (Figure 4.18). The ring would be inserted into the vagina. A cord was attached to the bottom of the sack to aid in the removal of the sack from the vagina.

Successive menstrual cups, like Hockert's, had a vaginal receiver attached to a receptacle. Until 1901, the receptacle was sizable, and would hang down between the thighs of the wearer, much like the trough- or canoe-shaped catamenial sacks. Starting in 1901, the vaginal cup and receptacle merged into a much smaller unit. Lang (1901, U.S.P. 679,478) did specify the dimensions of his smaller vaginal receptacle: "...ordinarily of about one and seven-eighths inches in diameter and three inches long; but these dimensions will vary, as the instrument will be made in several sizes." From these dimensions, it may be deduced the entire device would be worn internally and there would be no connecting sections that would hang between the thighs.

A final addition was added in 1917 by Norquist (U.S.P. 1,241,652). He added a small ring to the bottom of the retentive cup, in order to make removal easier. Appendix I is a listing of the menstrual retentive cups discovered during this study.

Summary

A variety of menstrual products were patented from 1854 through 1921. From an examination of the patents for menstrual technology, menstrual products can be divided into

S. L. Hockert.
Catamenial Sack.
Patented April 2, 1867.

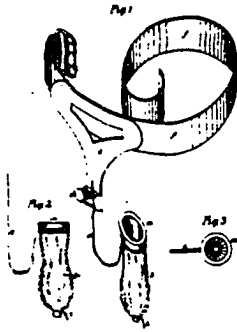

U.S.P. No. 70,843
November 12, 1867
S. L. Hockert

P. W. DAUTRICH.
CATAMENIAL SACK.
No. 435,900. Patented Mar. 19, 1896.

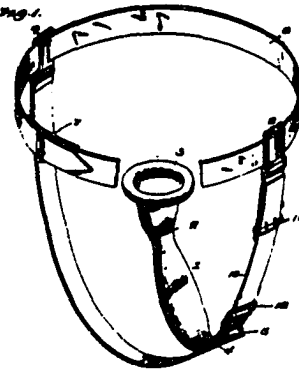

U.S.P. No. 535,960
March 19, 1895
Philip W. Dautrich

No. 679,478. J. R. LANG. Patented July 30, 1901.
MENSTRUAL RECEPTACLE AND UTERINE SUPPORTER.
(Invention filed May 12, 1898.)
On Demand

Fig. 1.

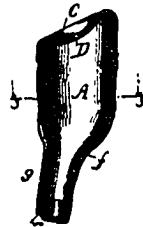

U.S.P. No. 679,478
July 30, 1901
Jacob R. Lang

J. JORGENSEN.
CATAMENIAL DEVICE.
1,113,561. APPLICATION FILED SEPT. 2, 1912. Patented Oct. 13, 1914.

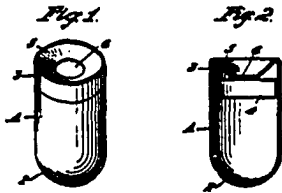

U.S.P. No. 1,113,561
October 13, 1914
John Jorgenson

L. E. NORQUIST.
CATAMENIAL APPLIANCE.
1,263,797. APPLICATION FILED AUG 9, 1917. Patented Apr. 23, 1918.

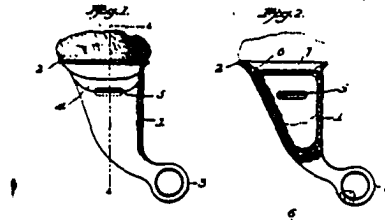

U.S.P. No. 1,263,797
April 23, 1918
Lester E. Norquist

Figure 4.18. Menstrual retentive cups.

six categories. The three most frequently patented menstrual products were (1) the belt or supporter, (2) the catamenial sack or menstrual receiver, and (3) the absorbent. The remaining categories of patented menstrual products were (4) attaching devices used in catamenial products, (5) catamenial garments or appliances, and (6) vaginally inserted menstrual retentive cups. Although patents for tampons were discovered, no reference in the patent literature documented their use for menstrual management.

Materials in the fabrication of menstrual products from 1854 through 1921 varied with the type of menstrual product patented. Menstrual products utilized current technologies and materials, such as vulcanized rubber, modifications of the safety pin, sponge rubber, and celluloid. Launderability and reusability were factors in selecting materials used for menstrual supporters, as well as catamenial sacks. Although reusability was also a consideration in the development of menstrual absorbents, disposable materials were employed more often in these products.

Although some menstrual products were extremely complicated, the general trend in the design of menstrual products was towards simplicity. A second trend identified was a move away from deep, trough-shaped catamenial sacks to flat, usually rectangular shaped napkin-holders. A third trend that originated in the nineteenth century was the

merging of the napkin-holder and the absorbent into one unit.
This ultimately resulted in the disposable sanitary napkin.

CHAPTER 5

AVAILABILITY AND MARKETING OF MENSTRUAL TECHNOLOGY

Attempts to locate evidence that commercial menstrual products were available and marketed to the public before the 1840s proved frustrating. One health-related periodical, *The Journal of Health* published from 1829 to 1830, was available for examination. Although *The Journal* addressed issues of physical education for girls, corseting, tight shoes, and the preservation of the complexion, no articles were published during this time about menstruation or any illness afflicting women. There were no advertisements for any personal products or services in this periodical.

A review of publications from the 1840s unearthed an advertisement for a personal product. *The Subterranean*, "Independent in Everything--Neutral in Nothing," published an advertisement in November 1845 for "Sherman's Trusses...improved suspensory bandages." Trusses support the lower abdominal regions in cases of rupture or hernia. Trusses may have been adapted for use in menstrual management; their configuration of straps, especially if used with a pad, would be suited for catching the menstrual discharge. Unfortunately, there was no picture of "Sherman's Trusses." A later reference to a menstrual product as an "Improved Female Supporter or Truss or Catamenial Sack" (Reeves, 1862, U.S.P. No. 34,845) indicated some trusses served two purposes, as

well as both sexes: Reeves "invented a new and useful Truss or Supporter [sic], for all purposes of both male and female use." At least one company, W.H. Horn and Brother of Philadelphia, manufactured trusses and menstrual supporters.

Suspensory bandages were usually for male use and provided protection in cases of venereal diseases (Farrell-Beck, 1994). However, two of the female patentees referred to their menstrual products as "suspensory bandages" (Jenness-Miller, 1891, U.S.P. No. 458,035; Pike, 1894, U.S.P. No. 529,750); in the patent texts, neither of these products was indicated as being for male use as well as female use. This suggested that the term "suspensory bandage" was used in two contexts during the nineteenth and early twentieth centuries.

In the nineteenth century, natural sponges were stock items found in most drug stores. As early as 1845, sponges were used by physicians to stanch menstrual flow, according to several professional journals, such as the *Western Journal of Medicine*, *Western Journal of Medicine and Surgery*, *Cincinnati Lancet and Observer*, *Cincinnati Lancet and Clinic*, *The Eclectic Medical Journal*, and *The Georgia Eclectic Medical Journal* (Farrell-Beck & Kidd, 1993). Who originated this idea, doctor or patient, is unknown. Sponge pads, combined with a truss, could have served as an early form of menstrual bandage.

No advertisement or written information was located that identified methods of marketing or distributing menstrual products during the 1850s and 1860s. In the 1870s, some advertisements appeared for menstrual products; the advertisements also revealed distribution methods.

Volumes I through III of *The Woman's Journal*, published from January 8, 1870 to December 28, 1872, contained advertisements suspected to be for menstrual products or services. In the November 12, 1870 issue, "LADIES' SUPPORTERS, invented and fitted by Mrs. L.W. Tuck" are advertised. Unfortunately, these products were not pictured. Mrs. Tuck of Boston also produced "Elastic Bandages & Trusses" (p. 357) and continued to advertise her products and services in *The Woman's Journal* for 12 consecutive weeks, ending with the February 11, 1871 issue. Why the advertisements stopped so abruptly is unknown.

Marketing and distribution of menstrual products may have originated not in retail sales but in door-to-door sales. A brochure from the 1870s (L. Bellais, personal communication with J. Farrell-Beck, October 13, 1993) for "Mrs. Smith's Universal Bandage Suspender For Supporting the Usual Bandage" not only extolled the virtues of this product, but also stated there were "AGENTS WANTED" specifically, "LADY AGENTS" (Figure 5.1). The use of door-to-door saleswomen may have diminished an individual's embarrassment when purchasing a menstrual

WOMAN'S COMFORTER!

MRS. SMITH'S
UNIVERSAL

BANDAGE SUSPENDER

For Supporting the Usual Bandage.

In adjusting the Suspenders, place the long strap at the back; the short strap in front has our brand on the under side of it, the point of the hook or holder being outward.

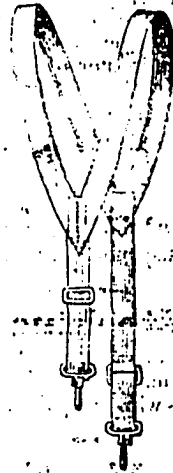

Catch the end of the bandage in the hook, and secure the point of the hook under the guard. It is a perfect safety fastening and can not be displaced.

No. 36 for ladies whose bust measure is less than 36 inches.

No. 40 for ladies whose bust measure is less than 40 inches.

No. 44 for ladies whose bust measure is more than 40 inches.

It can be used with any bandage a lady may wear; suspending the same from the shoulders, and is attached to the bandage, both front and back, by means of our *New Improved Safety Skirt and Bandage Holder*.

This Suspenders is the most convenient article for ladies' use ever known. Every lady knows the inconvenience and annoyance it gives them to suspend the bandage in the old way, with a string of band around the waist, as well as the uncertainty of its holding the bandage at all. Our *Improved Bandage Suspenders* will hold the bandage exactly in place, will hold it securely, is easily adjustable, and will give greater relief to the wearer than any thing else she may use for the purpose. They can be washed as easily as any under-garment without removing the hooks and slides.

No lady will be without one when she has once tried it or has seen it used.

They are sold by our LADY AGENTS at 60 cents.

QUEEN CITY SUSPENDER COMPANY,
Sole Proprietors and Manufacturers for the United States and Canada,
No. 179 Main Street, Cincinnati, O.

AGENTS WANTED.

Figure 5.1. Brochure from the 1870s advertising a suspender menstrual supporter. (Courtesy of L. Bellais. Best copy available.)

product. "Mrs. Smith's Universal Bandage Suspender" was manufactured by the Queen City Suspender Company of Cincinnati, Ohio. Because many nineteenth century inventors sold their patent rights but kept their names on the products (Warner, 1979), the supporter may have been invented by a "Mrs. Smith." The collected patents do not include a "Mrs. Smith" as a patentee of menstrual products. This product is very similar to Stephen Ellis's patent for a suspender menstrual product (see Figure 4.5), that was patented in 1875 (U.S.P. No. 169,245).

Pharmaceutical supply houses also distributed menstrual products (Farrell-Beck & Kidd, 1993). The 1880 McKesson & Robbins catalog listed among its many types of sponges "Small cups for ladies, 100 in a box" at a wholesale price of \$12.00. Because the McKesson & Robbins catalog listed these sponges separately from sponges used as pessaries, fine toilet sponges may presumably have been the type used during menstruation. *American Druggist*, in 1884, presented an advertisement for "Farr's Flexible Uterine Supporters" which included two menstrual receptacles (Figure 5.2). Menstrual receptacle No. 1 was patented June 24, 1884 by Farr (U.S.P. No. 300,770, Figure 5.3). The patents gathered in this study do not include a menstrual product like Receptacle No. 2; this product is similar to No. 1, but, instead of the vaginal receiving cup and receptacle, there is a disposable

Farr's Flexible Uterine Supporters.

Fig 1.

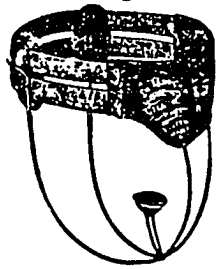

Improved Uterine Supporter.
Price, \$2.50 each.

Fig 2.

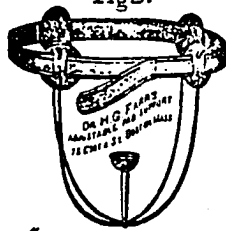

No. 2 Uterine Supporter.
Price, \$4.00 each.



Anteflexion and Retroversion Cups.—This Cut represents Flexible Stem Cup used with No. 1 and 2 Belts, that may be formed or bent by the physician to throw the cup at any angle desired and there remaining, thus receiving and holding the uterus, no matter what the displacements are.

I make three sizes Uterine Cups, Nos. 1, 2 and 3, and 2½ and 3 inch stems. Belts from 26 to 36 inches. In ordering give the size you want. All orders promptly filled.

The Prices, to physicians, of the foregoing goods, are as follows:
Improved Combined Abdominal and Uterine Supporter, as shown in Fig. No. 1, \$5.00
Combined Adjustable Pad Supporter, shown in Fig. 2, 4.00
Improved Belt, without Cup, as shown in Fig. 3, 3.00
Adjustable Pad Belt, without Cup, as shown in Fig. 4, 2.00
Plain non-elastic Belt, with Uterine Cup, 2.00
Flexible Uterine Cups, Protrusion or Anteflexion and Retroversion, 1.00
Pelvic Uterine Supporters, 2.00

FIG. 1.

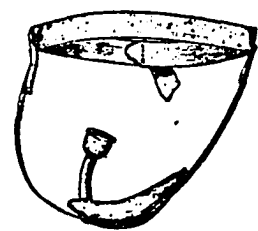

No. 1 Menstrual Receptacle.
Price, \$3.00 each.

FIG. 2.

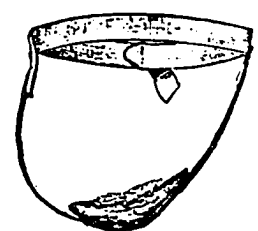

Menstrual Receptacle, No. 2,
with a year's supply of Absorbent,
Afterwards a year's supply for \$7.00

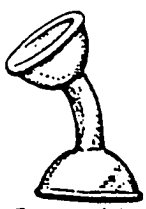

Patent Pelvic Uterine Supporter.
Price, \$3.00 each.



Dr. H. G. FARR, IMPROVED, FLEXIBLE CUP SYRINGE.
75 ESSEX ST. BOSTON MASS.
Price, \$1.00 each.



No. 2, 2 inch outside diameter.
No. 3, 2½ inch outside diameter.
No. 4, 3 inch outside diameter.
No. 5, 3½ inch outside diameter.
No. 6, 4 inch outside diameter.
No. 7, 4½ inch outside diameter.
Price to Physicians, 50 cents each, or \$5.00 per dozen

Sent by mail or express, as desired, upon receipt of the money, by P. O. order, Registered letter, Check or Draft payable to my order, or express, C. O. D., and return charges.

Dr. H. G. FARR, Sole Manufacturer, 75 Essex St., Boston, Mass.

P.S.—Send for Descriptive Circular.

Figure 5.2. Menstrual Receptacles No. 1 and No. 2, available from Dr. H. G. Farr, and advertised in the American Druggist, 1884.

(No Model.)

H. G. FARR.
MENSTRUAL RECEPTACLE.

No. 300,770.

Patented June 24, 1884.

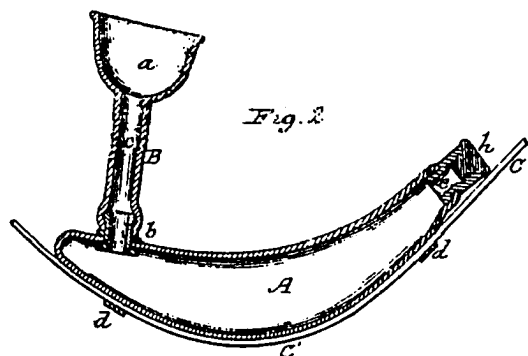
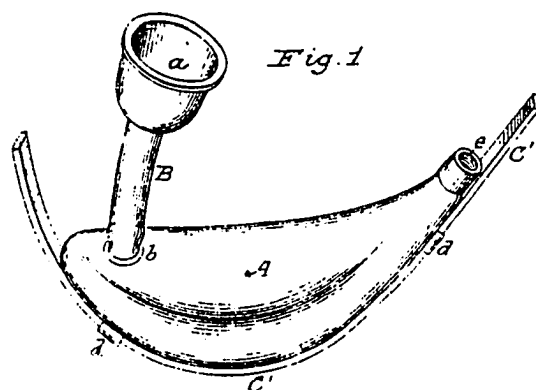

Witnesses:
E. J. Stearns
H. W. Stearns

Inventor
Hiram G. Farr,
per *Norman W. Stearns*
Atty

Figure 5.3. H. G. Farr's patent for "Menstrual Receptacle No. 1", U.S. Patent No. 300,770, June 24, 1884.

"Absorbent." These products could be purchased by a druggist for store sale, by physicians, or by the individual through the mail.

By the mid-1880s, advertising for commercial menstrual products appeared in popular magazines. In the November 21, 1885, issue of *Harper's Bazar*, the Lewis Stein Company of New York offered "Dr. Hill's" belt that supported hose and a napkin; there was no patentee by either name. By 1887, the catalog of Peter Van Schaack & Sons, a Chicago wholesale drug store supplier to local pharmacies, listed sanitary pads for sale. The manufacturer of these pads was W. H. Horn and Brother of Philadelphia, which started business in 1842 as a truss manufacturer. This pad consisted of cotton, gauze, and bandage, and was antiseptic. The 1887 Peter Van Schaack catalog also advertised "The Ladies' Elastic Doily Belt" manufactured by Horn in both silk and thread elastic with silk trimming. The Canfield Rubber Co. of New York was a frequent advertiser in many magazines and journals published during the late 1800s. This company manufactured all sorts of rubber goods, among them sanitary belts and various underpinnings, including dress shields. Canfield was also the United States' distributor for a British menstrual pad, Southall, that retailed small pads at \$.40 per dozen and large pads at \$.80 per dozen in 1888. Canfield continued as a company into the twentieth century (Farrell-Beck & Kidd, 1993).

I searched in other women's magazines published in the 1880s and the 1890s, among them *Good Housekeeping* and *The Ladies' Home Journal*. No advertisements for menstrual products or services were discovered. Then, at the University of Iowa, *The Jenness-Miller Quarterly Journal* was located.

The Jenness-Miller Quarterly Journal was edited by Mrs. Annie Jenness-Miller (or Jenness Miller; the hyphen appears to have been arbitrarily used by Mrs. Jenness-Miller as well as by the publishers). Devoted to promoting "Healthful and Artistic dress [sic]," readers were also provided with child-rearing advice, fiction, and informational articles on various subjects. This journal was a particularly welcome find; not only were advertisements for menstrual products found, but Mrs. Jenness-Miller was a patentee of a menstrual product.

Approximately 30 issues published from 1890 through 1898 were available for study. The publication went through several name changes, including *The Illustrated Quarterly*, *The Jenness Miller Illustrated Monthly*, *Woman's World* and *Jenness Miller Monthly*, and *The Gentlewoman*. Menstrual products were not advertised in every issue examined, but appeared more frequently in the Jenness Miller publications than in other periodicals examined. Unlike previous advertisements for suspected or real menstrual products, many notices included a sketch of the product.

I compared advertised menstrual products to the collected patents to discover if any of the patented items had actually been manufactured for sale. In the Autumn, 1890 issue of *The Jenness-Miller Quarterly Journal*, the "Bliss Woman's Band," manufactured by the Bliss Mfg. Co. of Minneapolis appeared, priced at \$.75 for a fitted band, and \$.30 for a plain band (Figure 5.4). The distinctive feature of the band was the use of center front and back loops to which the napkin or receiver could be attached. A "Catamenial Sack" with loops for attachment was patented on July 12, 1887, by Aurie Valon Robinson (U.S.P. No. 366,256); although not identical, the Robinson device is very similar (Figure 5.5).

Pictured for sale in the December 1891 issue of *The Illustrated Quarterly* was the "Woman's Perfect Suspensory Band" (Figure 5.6a). This had been patented on August 18, 1891, by Annie Jenness Miller of Dansville, New York, (U.S.P. No. 458,035, Figure 5.6b); in the ad copy the patent date was misprinted as August 1, 1891. Sold by Jenness-Miller Supplies of New York, the "Woman's Perfect Suspensory Band," was available at Jenness-Miller Supplies in New York City or through mail order for a price of \$1.00. This product furnished "extra warmth at a time when most women need it," protected the clothing, held the napkin in place more securely than "the old system of pinning it on," and was "pronounced perfect by physicians and all women who have tried it."

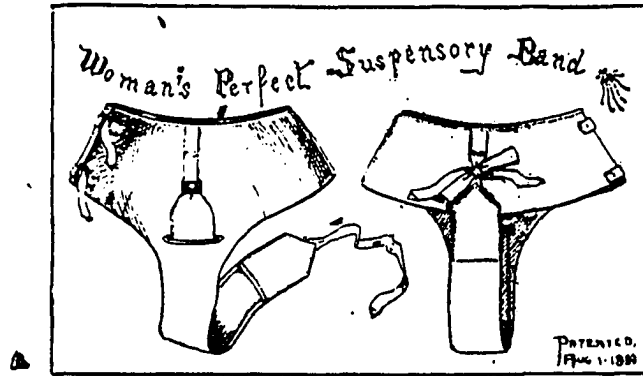

It is convenient, comfortable, self-adjusting.
 It requires no pinning.
 It is a perfect abdominal support and furnishes
 extra warmth at a time when most women need
 it.
 It protects the clothing from soiling.
 No accidents can possibly occur by which the
 napkin can be lost off as with the old system of
 pinning on.
 The abdominal yoke is so adjusted that there is
 no pressure anywhere.
 It can be laundered whenever worn, and is pro-
 nounced perfect by physicians and all women who
 have tried it.

PRICE. - - - \$1.00.

In ordering send waist measurement and measure taken over the full part of the abdomen.
 For sale at
THE JENNESS-MILLER SUPPLIES, 21 East 14th St., New York.

a

(No Model.)
 No. 458,035

A. J. MILLER.
 CATAMENIAL SACK.
 Patented Aug. 18, 1891.

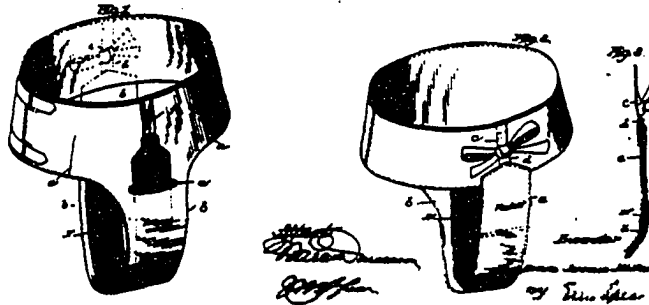

b

Figure 5.6 a. "The Woman's Perfect Suspensory Band" advertised in *The Illustrated Quarterly*, December 1891, Volume 5, No. 1, p. 22.

b. Annie Jenness-Miller's "Catamenial Sack" U.S.P. No. 458,035), patented August 18, 1891 (notice mistake on patenting date in ad copy.)

Curiously, there were no more advertisements for Mrs. Jenness-Miller's Perfect Suspensory Band in succeeding Jenness-Miller publications.

Jenness-Miller Supplies also acted as a distributor for "Arnold's," a company that sold knitted products, among them "Knit Antiseptic Form Fitting Diapers" and "Knit Absorbent Bandages" (Figure 5.7). Although there were no pictures or descriptions of these products, in all probability one or both of these products were used for menstruation. Knitted menstrual pads were in existence by the mid-1850s, as established from the menstrual pad in the Valentine Museum. The use of knitted menstrual products was health-related, as explained by Edward Dix, who patented a menstrual pad with a knitted covering in 1906 (U.S.P. No. 811,704). According to Dix, a non-woven outer covering kept the wearer warmer, because a "warp and woof" fabric was more "chilling" and not comfortable. Braided fabric was also used as an outer covering in menstrual pads. Darius Goff's 1883 "Fibrous Absorptive Pad" (U.S.P. No. 271,625) was "composed of a sliver of chemically-treated absorbent fiber inclosed [sic] within a braided seamless fabric." Although alternative fabrications were used, most patented absorbent pads or bandages had a loosely woven outer covering, such as cheesecloth or gauze.

In the June 1892 issue of **The Jenness Miller Illustrated Monthly**, John P. Horner of Boston placed an advertisement for

Mention this Journal.

ARNOLD'S Knit Antiseptic Form Fitting Diapers,
 \$4 to \$5.50 per Doz.
 Knit Gertrude Suits, \$7.50 to \$8.00 per Suit.
 Knit Accouchement Bands, \$4 per Pair.
 Knit Absorbent Bandages, \$4 per Doz.

—FOR SALE BY—
JENNESS-MILLER SUPPLIES,
 21 East 14th St., New York.

Send for ILLUSTRATED CATALOGUE.
 MENTION this JOURNAL.

Figure 5.7. Advertisement for "Arnold's Knit Absorbent Bandages" in *The Jenness-Miller Illustrated Quarterly*, March 1892, Volume 5, No. 2, p. 11.

The J. M. Woman's Band.
 AGENTS WANTED.
 Sample by Mail, - 75 Cents.
JOHN P. HORNER,
 Boston, Mass.
 Mention this Journal.

Figure 5.8. Advertisement for "The J. M. Woman's Band" in *The Jenness-Miller Illustrated Monthly*, June 1892, Volume 5, No. 3, p. 22.

"The J.M. Woman's Band" (Figure 5.8). No retail price was given for this product. A sample would be sent to prospective "Agents" through the mail for \$.75. Did "J.M" stand for Jenness-Miller? Did Mrs. Jenness-Miller sell her manufacturing and distribution rights to the Woman's Perfect Suspensory Band? Unfortunately, no picture of the J.M. Woman's Band accompanied the advertisement and no other information was located to resolve this coincidence. "

The September 1893 issue of *The Jenness Miller Illustrated Monthly* featured "The Comfort Belt and Supporter," a combined menstrual belt and stocking supporter (Figure 5.9a). Unlike the 1870s suspender menstrual supporter (see Figure 5.1), the straps for the menstrual supporter and the hose were suspended from a waistbelt. The ad, placed by G.W. Hoyt & Co., "Sole Manf's [sic]" of Chicago, pronounced "AGENTS WANTED EVERYWHERE." If the consumer did not find these items from their "dealer" the items could be ordered directly from the "makers." Unlike previous menstrual products, consumers had a choice of colors and fabrics for this product. For \$.50, the supporter was available in "Black and White Sateen"; for \$1.50, in "Black and White Satin." The only patent that is similar in shape to Hoyt's was one registered to Edward C. Hornor in 1894 (U.S.P. No. 520,113, Figure 5.9b). However, neither Hoyt nor Hornor should be credited with this idea. The first menstrual belt that also acted as a stocking

THE COMFORT Belt and Supporter

is a favorite, because it has Patent
"ROYAL" Clasps, which do not cut the
stocking like old-style Fasteners.

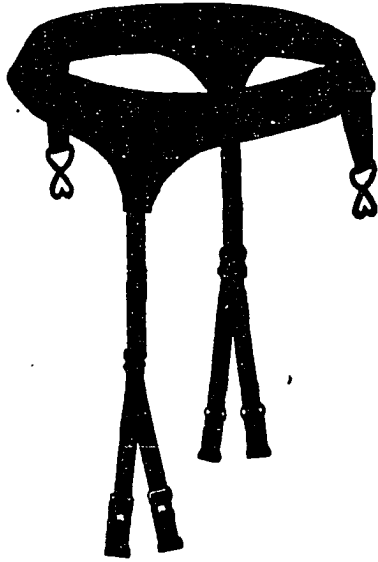

IT ALSO HAS

PAT. DOUBLE FISH-HOOK CLASP

front and back FOR SPECIAL USE.
Simplicity itself to fasten and unfasten, but
CANNOT UNFASTEN OF ITSELF.

If you cannot find them with your dealer
then order direct from the makers.

AGENTS WANTED EVERYWHERE.
GIVE SIZE OF WAIST.

Black and White Sateen, by mail, \$0.50
Satin, " 1.50

G. W. HOYT & CO., Sole Manf's,
241½ MONROE ST., CHICAGO.

a

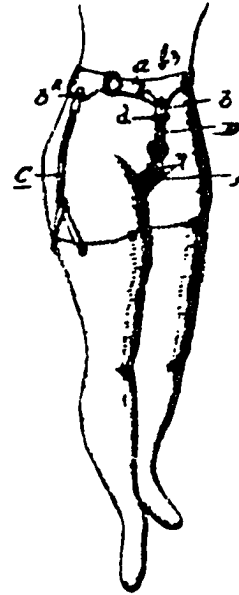

b

Figure 5.9 a. Hoyt's "Comfort Belt and Supporter in The
Jenness-Miller Monthly, September 1893,
Volume 6, p. 22.

b. Edward Hornor's "Catamenial Sack" (U.S.P.
No. 520,113) patented 8 months after Hoyt's
advertisement (May 22, 1894).

supporter was patented in 1868 by Elizabeth Daniels (U.S.P. No. 81, 479, Figure 5.10).

In the June, July, and August 1896 issues, *Woman's World* and *Jenness Miller Monthly* advertised and distributed "Absorbent Diaper Cloth" (Figure 5.11). For \$3.00, the consumer purchased 10 yards of diaper cloth (and received a one-year magazine subscription). The advertisement claimed this cloth was "recommended by the highest authorities in sanitary dress" and was the "best absorbent cloth manufactured for diapers." In the nineteenth century, "diaper" referred to an infant apparel item, as well as a menstrual cloth. The diaper cloth in the advertisement is described as a "jersey webbing," which is a single knit. Because diaper cloth is traditionally made by dobby weave techniques, this may be a knit fabric simulating a woven one. This ad also appeared in the May 1897 issue.

In August, 1896, The Antiseptic Fibre Co. of Brooklyn, New York, advertised "Spongia Absorbent Napkins" at a price of \$.30 per dozen (Figure 5.12). A sample could be procured for \$.05. These napkins were "FOR WOMEN'S WEAR" and were "for sale at all Dry Goods Stores" as well as available through mail order. Spongia Absorbent Napkins were advertised again in the September and October 1896 issues.

Also in the August and October 1896 issues of *Woman's World* and *Jenness Miller Monthly* were advertisements for

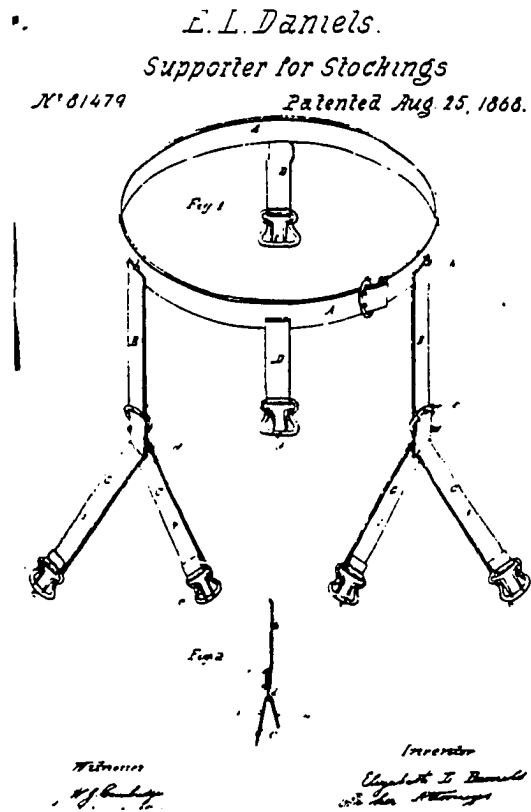

Figure 5.10. Elizabeth Daniel's "Stocking Supporter,"
 patented August 25, 1868, U.S. Patent No.
 81,479.

**Absorbent
Diaper Cloth,
Jersey Webbing.**

This cloth is the best absorbent cloth manufactured for diapers. It is recommended by the highest authorities in sanitary dress. By arrangement with the manufacturers we can supply this Absorbent Jersey Webbing, 30 inches wide, at 30 cents per yard. For \$3 we will send 10 yards and give one year's subscription free to the WOMAN'S WORLD AND JENNESS MILLER MONTHLY.

**WOMAN'S WORLD and
JENNESS MILLER MONTHLY,
908 Temple Court Building,
New York City.**

Figure 5.11.
Advertisement for
"Absorbent Diaper Cloth"
in Woman's World and
Jenness Miller Monthly,
June 1896, Volume 6, p. 18.

SPONGIA FOR WOMAN'S WEAR,
30c. dozen.

**ABSORBENT
NAPKINS**

For sale at all Dry Goods Stores.

Sent by mail on receipt of price. Samples 5c.

**THE ANTISEPTIC FIBRE CO.,
1202 ATLANTIC AVE., BROOKLYN, N. Y.**

Figure 5.12.
Advertisement for
"Spongia Absorbent
Napkins" in Woman's
World and Jenness
Miller Monthly,
August 1896, Volume
9, No. 8, p. 19.

HARTMANN'S WWS (Women's
Napkins.)

Send 10c. for sample and circular. CANTONMENT WAREHOUSE
Empire State Bldg. Co., 44 Broadway, New York.

Figure 5.13. Advertisement for "Hartmann's WWS" in Woman's
World and Jenness Miller Monthly, October 1896,
Volume 9, No. 10, p. 19.

"Hartmann's WW^s" or "Women's Napkins" sold by the Hygienic Wood Wool Co. of New York City (Figure 5.13). A sample and circular would be sent for \$.06 to potential "canvassers." Ads for Hartmann's are repeated in the October and November 1896 issues. These are most likely the same product as "Hartmann's Hygienic Towelettes for Ladies'" advertised in the Harrod's of London 1895 catalog (cited in Schroeder, 1976, p. 107).

Less candid copy may have represented companies involved in menstrual product manufacture and marketing, represented in an intriguing advertisement found in the October 1896 issue of *Woman's World and Jenness Miller Monthly*. If a stamp was enclosed in the request, F. H. Young of Toledo, Ohio, furnished "MARRIED LADIES" with a catalog of "Rubber Goods, Syringes" and other "Ladies' Specialties." To determine intended end use of such products, I examined more closely the jargon utilized in product descriptions. Some of these goods may have been contraceptive products, as well as menstrual products. Nineteenth century written references to reproductive products or services usually contained an element of subterfuge, particularly after the passage of the Comstock Law in 1873 (Kerber, 1991), sections of which outlawed the sending of any contraceptive information or materials through the mail (or any materials that could be construed as contraceptive).

In December 1896, a new menstrual product company began advertising in *Woman's World and Jenness Miller Monthly*. The Absorbent Fibre Company of New York City promoted "Spungia Napkins" as "Antiseptic and Absorbent" (Figure 5.14). Other benefits included comfort, durability, and cleanliness; the napkins had a deodorant and were supplied with a "patent suspensory"; additional suspensories could be purchased for \$.10 a dozen. (The use of the word "patent" may not refer to a legal document; it may merely mean a new and unusual item.) The health aspects of Spungia Napkins were underscored by a report from "an eminent New York specialist" who reported in one of his lectures "that 80 per cent of the diseases common to women was due to their not using antiseptic absorbent napkins." Even though Spungia Napkins were available at "all first-class dry goods and drug stores," "lady agents" were "wanted everywhere." Spungia Napkins sold for \$.30 a dozen. Other ads for Spungia Napkins appeared in the March and April 1897 issues with a reassuring addition: "Mail orders in charge of competent lady" (Figure 5.15). The name of the company and product is remarkably similar to the earlier product Spongia, sold by the Antiseptic Fibre Company of Brooklyn. If imitation (or near-plagiarism) is the sincerest form of flattery, might it not also be an indication of the success of the earlier advertised Spongia Absorbent Napkin?

FOR WOMAN'S WEAR.

SPUNGIA NAPKINS.

Antiseptic and Absorbent.

ENDORSED BY LEADING PHYSICIANS AS
THE BEST SANITARY NAPKIN.

COMFORTABLE, because they are soft and pliable.

HEALTHFUL, because they are antiseptic and absorbent.

CLEANLY, because they are deodorant, and are supplied with our patent suspensory.

An eminent New York specialist recently said in one of his lectures that 80 per cent. of the diseases common to women was due to their not using antiseptic absorbent napkins.

At all first-class dry goods and drug stores, 30 cents per dozen.

Lady agents wanted everywhere.

If your dealer hasn't our goods, send us 30 cents—25 cents of which is for postage—and we will mail you a sample dozen.

ABSORBENT FIBRE COMPANY.

51 Franklin Street, New York.

Mention Woman's World and Jenness Miller Monthly when you order these napkins.

Figure 5.14. Advertisement for "Spungia Napkins" in *Woman's World and Jenness Miller Monthly*, December 1896, Volume 9, No. 12, p. 18 (best copy available).

FOR WOMAN'S WEAR.

Spungia Napkins.

Antiseptic, Absorbent.

Recommended by all leading physicians as the best napkin for use by women.

At all first-class Dry-Goods and Drug Stores.
30 Cents per Dozen.

Or by mail, postpaid, 40 cents.
Mail orders in charge of competent lady.

SPECIAL.—Sample bundles of half-dozen sent for 25 cents. Stamps will do.

FREE.—Our patented Suspensory is supplied with each order.

Additional Suspensories, 10 cents per dozen.

ABSORBENT FIBRE CO., Dept. G.,
51-55 Franklin St., New York.

Mention Woman's World and Jenness Miller Monthly when you order these napkins.

Figure 5.15. Advertisement for "Spungia Napkins" whose mail orders were now "in charge of competent lady." In *Woman's World and Jenness Miller Monthly*, March 1897, Volume 10, No. 3, p. 26.

Another wood wool napkin was advertised in *Woman's World and Jenness Miller Monthly* in January 1897 (Figure 5.16). The Wood Wool House of New York City offered "The Empress 'Wood Wool' Absorbent" purported to be "a radical departure from old methods and unique combination of inventive genius for the improvement of such a widely used article." This product was also referred to as "W.N" or "Women's Napkins." No retail prices were listed, nor were there any requests for agents or retail sale information. A sample could be obtained by mail for \$.10.

C.E. Frankenthal Co., Incorp. of Chicago advertised "The Sanitary Menstruation Belt" or "Woman's Sanitary Belt" in the May, 1897, issue of *Woman's World and Jenness Miller Monthly* (Figure 5.17). Alleged to "SAVE tearing your underclothes by pinning to them," this belt, which saved "time, trouble and expense," utilized the same hooks or clasps found on Hoyt's Comfort Belt and Supporter advertised in 1893. The special introductory price of this belt was \$.25; there was a money-back guarantee "if Asked for." Again, "agents" were wanted. The address of the Frankenthal Co. was the W.C.T.U. Temple; there is no information in the advertisement establishing an affiliation with the Women's Christian Temperance Union. The Frankenthal Co.'s belt does not appear in any of the collected patents.

THE EMPRESS
"WOOD WOOL"
 (Women's Napkins)
W. N. ABSORBENT.

There have been placed upon the market many makes of Absorbent Napkins for woman's wear, but none have ever reached that state of Absolute Perfection as the "Wood Wool" make. It would be impossible in this small space to thoroughly explain the merits of "The Empress," but Physicians recommend them to all patients as the Ideal Napkins for Health, Comfort and Safety. Thoroughly Sterilized and Aseptic. A radical departure from old methods and unique combination of inventive genius for the improvement of such a widely used article. Sample by mail 10c. Address: **WOOD WOOL HOUSE, Box 10 Floral Park, New York.**

Register, Woman's World and Jenness Miller Monthly when placed in this advertisement

Figure 5.16. Advertisement for "The Empress "Wood Wool" Absorbent" in *Woman's World and Jenness Miller Monthly*, January 1897, Volume 10, No. 1, p. 26. (Best copy available).



SAVE Tearing your underclothes by pinning to them. The Sanitary Menstruation Belt saves time, trouble and expense. BELT made of lean, light, durable and form fitting. PATENT SERRS easily adjusted, quickly unloosened. Can't work loose. Far superior to ordinary safety pin. **TRY ONE.** Belt fits any time. **Introductory PRICE 36 CTS; postpaid. Money Back if asked for.** **AGENTS WANTED.** Write for terms. **C. E. FRANKENTHAL CO.,** Importers, W. C. T. C. Temple, Chicago. Illustration of Woman's World and Jenness Miller Monthly, May 1897, Volume 10, No. 5, p. 32.

Figure 5.17. C. E. Frankenthal Co.'s "Woman's Sanitary Belt" in *Woman's World and Jenness Miller Monthly*, May 1897, Volume 10, No. 5, p. 32.



Ladies Earn Money
Selling our **HYGIENIC COMFORT BELT and SUPPORTER.** Belts at eight. Buxton clasps that can't cut the stockings; double "hook" fastener front and back for special use; easy to fasten and unfasten, but can't unfasten themselves. No need at store. Sample by mail, sixteen 30c., cotton-silk hose supporter, 60c. satin, 81c. Colors black and white. Give waist measure. Agents wanted. Circular free. **JULIA A. BROWN, 122 Washington St., Boston.** Illustration of Woman's World and Jenness Miller Monthly, May 1897, Volume 10, No. 5, p. 29.

Figure 5.18. Julia A. Brown's advertisement for "our Hygienic Comfort Belt and Supporter" in *Woman's World and Jenness Miller Monthly*, May 1897, Volume 10, No. 5, p. 29. This appears to be the same product manufactured by G. W. Hoyt & Co. (see Figure 5.9a).

Also appearing in the May 1897 issue was the "Hygienic Comfort Belt and Supporter" distributed by Julia A. Brown of Boston (Figure 5.18). The belt appears to be identical to Hoyt's Supporter advertised in September 1893 (see Figure 5.9). "Not sold in stores," the supporter was also a way for "LADIES" to "EARN MONEY." Again, the mail-order customer had a choice between colors (black and white). The prices of these supporters were lower than Hoyt's: \$.35 for sateen, \$.60 for "sateen-silk," and \$1.00 for satin.

There were no advertisements for menstrual products in the June 1898 issue of *The Gentlewoman*. Scattered throughout this issue, however, were line drawings of underclothing, including corsets. On one of the corset illustrations was a center front suspended strap with a hook or a clasp on the end (Figure 5.19). Although no explanatory text accompanied this sketch, the strap most probably was designed to support a menstrual receiver or napkin. This suspension strap preceded Cortland's 1901 patented attaching device (U.S.P. No. 686,028, see Figure 4.14).

Advertisements for commercial menstrual products appeared in other late nineteenth century periodicals. In 1894, The Ladies Supply Company and H. E. Brown & Co., both of Chicago, sought lady agents through classified ads placed in *The Delineator*. Other women entrepreneurs, such as Mrs. J. A. Kinsman & Co., of Chicago offered "any Lady a Valuable Secret

on further informa-
 / admirable way of
 healthfulness and
 ing, is at liberty to
 Hor of THE GENTLE-

FASHIONABLE HOUSE

the every gown which
 e with
 at and
 jaunty
 belts,
 at the
 some
 gowns,
 place
 er of

es are
 gowns,
 and the wide, ele-
 atin and moire will

f the world never
 as her experience
 on become common
 discriminating and
 woman grasps at
 a, believing she has
 fashion. That is
 upon a woman who
 the most startling
 way of hats with
 rs and chiffon, rows
 bons, and other ex-
 ty in the season ab-
 r sightseers before
 ey were displayed.
 t store which turns
 the multitude has
 these incongruous
 sees a woman with
 ightly drawn back
 ad a mass of mull
 id tax the dignity
 e showily dressed
 tention by her per-
 eps along the dusty
 of head a mass of
 velvet—that shade
 high ceremonials
 para. To succeed
 garments is more to
 cost and whether
 liked the articles
 If they are not ap-
 the figure and the
 means of the pur-
 down beforehand
 e and money only
 ons.

tic dressing which
 is this: shams and
 ays. inartistic. A

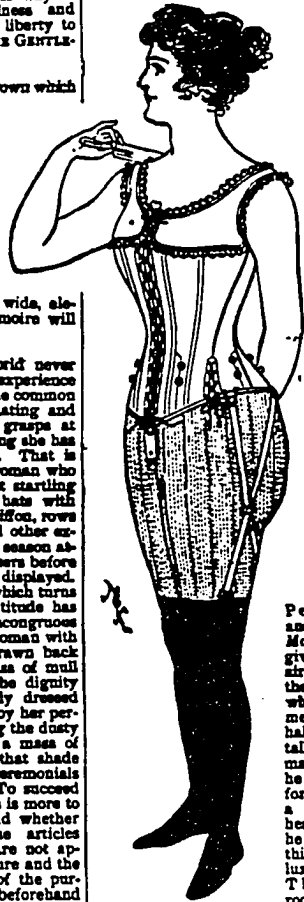

BY
 A
 was
 Will
 ed
 the
 way
 cit
 but
 uni
 fact
 mor
 ble.
 hot
 rock
 a n
 rock
 in
 shaj
 hall
 thro
 cent
 hom
 be
 crin
 la p
 pair
 the
 but
 cost
 a ot
 cus
 form
 trea
 off
 Tur
 Persi-
 and fig
 Moorist
 give the
 air of
 the pl
 who sa
 me see
 hall an
 tall yo
 manner
 he is,"
 form an
 a very
 hearted
 he sho
 this hall
 luxurious
 The d
 room
 paneled
 tapestry
 respond

furniture and the gilt mirrors; the
 tion room will be done in printed
 sumptuous, golden-brown tones, t
 erand with the mahogany furnit-

Figure 5.19. The small strap attached to the front center dip of the corset was most likely used to support a menstrual pad or receiver. In *The Gentlewoman*, June 1898, Volume 12, No. 3, p. 21.

that cost me \$5.00, and a rubber shield for 30 cents" (Farrell-Beck & Kidd, 1993). As mentioned previously, assumptions concerning advertising copy written in coded language must be cautiously made. As with the 1896 advertisement written by F. H. Young of Toledo, Ohio, this may have been an advertisement for a contraceptive. Apple (1984) discovered another brand of menstrual pads advertised in the **New Crusade** in 1899. "Sanatonap" was lauded as

Indispensable to the woman who travels.
Economical for the woman who boards.
Convenient for the woman who stays at home (p. 286)

The most frequently cited source for United States menstrual products and a clue to their distribution are the mail order catalogs of Sears, Roebuck and Montgomery Ward. No Montgomery Ward catalog could be located and examined for this study. Schroeder (1976) described two specific menstrual products available in the 1895 Montgomery Ward catalog:

Ladies Faultless Serviette Supporter, made of soft sateen with a rubber band across hips. Meets with universal approval. Sizes are every inch from 22 to 36. \$.25 each.

The Faultless Serviette or Absorbent Health Napkin; economical, comfortable, healthful. Recommended by physicians and fast superseding birdseye linen, more absorbent, antiseptic, no washing, burned after using, invaluable while traveling, cheaper than laundering. Medium size \$.50/dozen (p. 107)

Unfortunately, he did not include pictures of these items.

Reprinted editions of the 1897 and 1902 Sears, Roebuck catalogs were available for examination. I compared the

menstrual products offered for sale in the Sears, Roebuck catalogs with menstrual product patents in an attempt to find a link between invention and commercial sales.

I searched the 1897 Sears, Roebuck Catalogue index for menstrual products. No direct references to menstruation or catamenia appeared in the index. Instead, other entries suggested possible menstrual products:

Abdominal Supporter.....	32
Absorbent Pads.....	32
Cloth, Sanitary.....	323
Cotton Diapers.....	295
Hose Supporters, Ladies'....	322
Ladies' Antiseptic Pads.....	32
Ladies' Safety Belts.....	323
Pads, Ladies' Absorbent.....	32
Rubber Sundries.....	32-35
Safety Belts, Ladies.....	323
Sponges.....	330
Supporters, Abdominal.....	32

After I examined the copy and the product sketches, some products were discovered to be menstrual products. The first of these were the "Ladies' Elastic Doily Belt" and an "Antiseptic and Absorbent Pad" (Figure 5.20). The "Ladies' Elastic Doily Belt" as well as menstrual pads were initially sold by Peter Van Schaack, also based in Chicago, and it is plausible the products for sale in the Sears catalog were the same products advertised in the Van Schaack catalog. As usual, Sears undercut the prices: Van Schaack offered the belt wholesale for \$1.00 and the pad for \$.75 a dozen; Sears sold the belt directly to the consumer for \$.65 and the pads for \$.40 a dozen. Sears pictured the belt in a line drawing;

D 970 Ladies' Elastic Doily Belt. Silk Trimmings and Silk Elastic. This belt, made in both silk and thread elastic, is worn by ladies during their menstrual period, for the convenience of attaching the napkin and is indispensable for comfort. In walking or sitting, it conforms to the varying positions of the body, thereby preventing all tendency to chafe. It is easily adjusted, and will not interfere with the other garments.

Each.....\$0.65

D 971 Antiseptic and Absorbent Pad. These pads, made from cotton, gauze and bandage, have been rendered "Antiseptic," thus making a very convenient and entirely safe substitute for the old style napkin and are highly recommended by all our prominent medical authorities. For traveling and especially for long voyages, they are a necessity, as their antiseptic nature prevents them from carrying germs of disease and enables their being kept until convenient to burn, or otherwise disposed of. Their cheapness combined with their downy softness, absorbent and antiseptic properties, recommend them for regular use, as a good substitute for the old style cumbersome, hot and chafing napkins.

Box of one doz.....\$0.40

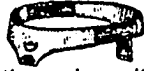

25322 Ladies' Belts with hose supporters. Per pair.....18c
Per dozen.....\$1.80



Figure 5.20.
"The Ladies' Elastic Doily Belt" and menstrual pads, advertised in the 1897 Sears, Roebuck Catalogue, p. 32.

Figure 5.21.
"Ladies' Belt with hose supporter" that combined a menstrual supporter with stocking supporters, in the 1897 Sears, Roebuck Catalogue, p. 322.

Ladies' Black or White Combination Belt.

25330 Ladies' Black or White Combination Belt. Made of good satton, with hose supporters and points for safety belt. Sizes 22 to 30.

Each 25c; per dozen.....\$2.50



25334 Ladies' Safety Belts, made of satton, rubber band across hips. Sizes 22 to 30. Ask for one inch larger than your exact waist measure. (Sizes every inch). Each 21c; per doz...\$2.45

25338 "Serviette" Sanitary Cloth. These Serviettes are made of the finest absorbent cotton, with a layer of absolutely impervious material, which insures cleanliness. Absolutely antiseptic, ready for instant use. These Serviettes possess from three to four times the absorbent qualities of the best toweling. Recommended by the medical profession as indispensable in every ladies wardrobe.

Each, 4c; per dozen.....\$0.40

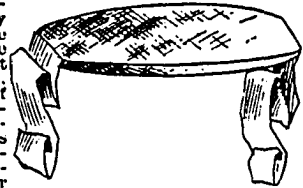

Figure 5.22. Menstrual products advertised on page 323 of the 1897 Sears, Roebuck Catalogue.

a comparison was made with the collected patents. Although the shape of the belt is similar to some of the menstrual supporters patented, the exact combination of parts and materials is not an exact match. The pad was not pictured.

Other menstrual products advertised by Sears included "Ladies' Belts with hose supporters" that combined a menstrual belt and hose supporters and was priced at \$.18 a piece or \$1.90 per dozen (Figure 5.21). A product combining suspenders for holding up hose and "points" for supporting the "safety belt" was the "Ladies' Black or White Combination Belt," \$.25 each or \$2.55 per dozen (not pictured). Pictured on the same page as the "Combination Belt" were the "Ladies' Safety Belt" and " 'Serviette' Sanitary Cloth" menstrual pads (Figure 5.22). The "Safety Belt" sold for \$.65 per piece or \$2.45 a dozen; the "Serviettes" were \$.40 per dozen, or \$.04 per piece.

Sears sold cotton and linen "Sanitary Diaper cloth...chemically pure and absorbent." Diaper cloth may have been sold for reusable menstrual cloths as well as infant diapers; there is no reference to end use in the Sears ad copy. Diaper cloth sold in 10 yard lengths and in widths of 18, 20, 22, or 24 inches. Cotton diaper cloth was less expensive than linen diaper cloth: an 18 inch wide length of cotton diaper cloth was \$.45 per piece, and an 18 inch wide length of linen diaper cloth was \$1.25 per piece.

Sponges could be purchased through Sears, Roebuck mail order. A "Very Fine 'Small Eye' Sponge," suitable for "surgical and nursery use" at \$.06 each as well as a slightly larger sponge for "toilet use" or shaving at \$.05 1/2 each were available. There was no reference to the use of these sponges in menstrual management.

When I compared menstrual products advertised in the Jenness Miller publications and those advertised in the 1897 Sears, Roebuck Catalogue, I found no identical matches. Menstrual products sold by Sears, Roebuck were less expensive than those sold through the Jenness Miller publications.

Women could also purchase menstrual products from sources other than drug stores and mail order houses. Department stores carried sanitary napkins at least by 1887, documented by advertisements for Southall's Sanitary Towels that were marketed in retail stores such as John Wanamaker; Strawbridge and Clothier; and Marshall, Field and Co. Lingerie and corset departments purveyed women's products, including menstrual items. Plackarding the prices, which seems to have been a practice in department stores by the 1890s, may have helped diminish some of the embarrassment when making such a purchase (Farrell-Beck & Kidd, 1993). In all probability by 1900, literate women were aware of the existence and availability of commercial menstrual products. According to an entry in Cole's Encyclopedia of Dry Goods, published in 1900

The sanitary napkin made especially for women has within recent years become a staple commercial article. They are made of various materials, the most common kind being composed of a number of strips of absorbent cotton, with an impervious waterproof lining on the lower side, the whole encased in soft, fine outing cloth. Cheaper varieties are made without the waterproof lining (Cole, 1900, p. 374)

Menstrual products were advertised by Sears, Roebuck throughout the early twentieth century. From the index to the 1902 Sears, Roebuck Catalogue, possible menstrual products included

Abdominal Bands.....	466
Abdominal Belt.....	466
Belts, Abdominal.....	466
Bandages.....	466
Bandages, Surgeons'.....	467
Diaper Cloth.....	864
Diapers.....	1074
Elastic Stockings, Bandages, Suspensories and Abdominal Belts.....	466
Hose Supporters.....	940-941
Corsets.....	942-944
Protectors, Full Dress.	994
Protectors, Venus.....	463
Sponges.....	455
TRUSSES.....	464-466
Umbilical Belt.....	466

Unlike the publishers of the 1897 Sears, Roebuck Catalogue, the publishers of the reprinted 1902 edition did not include all of the pages of the catalog, stating

We have retained the continuity and flavor of the original, but in order to keep within a useful format of over 700 pages, we have omitted those pages which were mostly repetitious. Nevertheless, where we believed the present-day interest in a particular section was great enough for preservation in its entirety, such as the Gun Section, we did preserve it (Publishers' Note, Introduction, no pagination)

The following pages were deleted by the publishers: pages 466, 467, 864.

"Ladies' Safety Belt and Hose Supporters" at \$.20 each and "Ladies' Safety Belts" at \$.14 each were available (Figure 5.23) and appeared to be the same products advertised in the 1897 catalog. Sears' "Sanitary Napkin" was recommended to be used with the "Ladies' Safety Belt and Hose Supporters" and was priced at \$.03 each (Figure 5.23--copy only, no picture). "Serviettes" were still available, now in a choice of medium or large size, priced at \$.03 each (Figure 5.24). In another department, "The Venus or Sanitary Protector" sold for \$.47 (Figure 5.25). "Absorbing Pads or Napkins" for this protector, made of "especially prepared muslin and medicated cotton" were \$.25 per dozen, and a six months' supply of "Sanitive [sic] Wash" could also be purchased for \$.20 per bottle, but was "unmailable on account of weight."

A review of the collected patents revealed Mathis & Simon patented a "Catamenial Sack" (U.S.P. No. 853,708, Figure 5.26) almost identical to the "Venus." This patent, which was filed July 27, 1906, was not granted until May 14, 1907, five years after the publication of the 1902 Sears, Roebuck catalog.

Sponges were still sold by Sears, Roebuck. By 1902, more types of sponges were available, presumably for more varied end uses. In addition to the "small eye" and the "small" toilet-sized sponges, sponges designated specifically for use

Ladies' Safety Belt and Hose Supporters.



No. 18R4744 Ladies' Combination Safety Belt and Hose Supporters. Belt made of good sateen and good Hale side elastics. Colors, black and white. Sizes, 22 to 36. Give waist measure. Price, each.... 30c
If by mail, postage extra, each, 3 cents.

We recommend our Sanitary Napkin No. 18R4753 at 3 cents each to be used with the above Combination Belt. Ladies who have used them once will never be without them.

Ladies' Safety Belts.

No. 18R4743 Ladies' Safety Belts, made of sateen, rubber band across hips. Easy and convenient. Sizes, 22 to 36. Ask for one inch larger than your exact measure. Color, white only. Sizes every other inch; give waist measure. Price, each..... 14c
If by mail, postage extra, each, 2 cents.



Figure 5.23. Menstrual belts advertised in the 1902 Edition of the Sears, Roebuck Catalogue, p. 940.

Serviettes.



No. 18R4753 Serviette Sanitary Cloth. These serviettes are made of the finest absorbent cotton, with a layer of absolutely impervious material, which insures cleanliness. Absolutely antiseptic, ready for instant use. These serviettes possess from three to four times the absorbent qualities of the best toweling. Recommended by the medical profession as indispensable in every lady's wardrobe. Medium and large sizes. Price, each..... 3c
If by mail, postage extra, per dozen, 3 cents.

Figure 5.24. "Serviette" menstrual pads in the 1902 Edition of the Sears, Roebuck Catalogue, p. 941.

THE VENUS OR SANITARY PROTECTOR.

NOW ONLY 47c EACH! No woman who values comfort, cleanliness and health should be without it. The only practical protector. Perfect in fit. Safe in use.

THE ENORMOUS SALE of this grand protector has caused us to manufacture it in such immensely large quantities, to reduce the cost of production to such an extent, that we are today in a position to offer this valuable appliance for the never heard of low price of 47 cents each.

THE VENUS PROTECTOR is made of a transparent India rubber sack which is very silky, soft and pliable and also very strong. This sack readily admits a napkin or any other soft substance like cheesecloth or cotton, and will hold it securely in the proper position. The belt is made of the very best lisle, non-elastic. The strap to which the sack is buckled is made of a superior grade of lisle elastic, which gives with the different movements of the body, thus keeping the protector always in the right place.

THE VENUS OR SANITARY PROTECTOR will save its cost in washing and bleaching. It is absolutely water-proof and thereby positively prevents soiling of the undergarment. Each protector comes put up in a neatly finished box with full and explicit directions. With proper use will last a lifetime. After use each month all that is necessary is to clean it with a damp cloth or sponge. In ordering give waist measure.

POINTS OF EXCELLENCE in the Venus or Sanitary Protector. It is perfectly sanitary, comfortable, pliable and non-irritating; easily adjusted and readjusted, and indispensable to women walking, riding or traveling. Always clean and ready for use. Feels cool in summer and keeps the wearer from cold in inclement weather. Retail price of the Venus or Sanitary Protector, \$1.50 each.

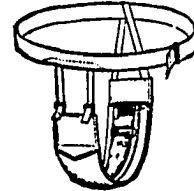

Engraving shows the napkin in place, ready for use.

No. RR1850 Our special price, each.....	47c	
If by mail, postage extra, each, 5 cents.		
Absorbing Pads or Napkins for the protector, made of especially prepared muslin and medicated cotton.		
No. RR1850C Price, per dozen.....	250	
If by mail, postage extra, 5 cents.		
A bottle of Sanitive Wash in concentrated form, sufficient for six months' supply, put up especially to be used in connection with the celebrated Venus or Sanitary Protector.		
No. RR1855 Sanitive Wash. Our special price, per bottle.....	200	
Unmarketable on account of weight.		

Figure 5.25. The "Venus" Protector and other personal products advertised in the 1902 Edition of the Sears, Roebuck Catalogue, p. 463.

No. 853,708.

PATENTED MAY 14, 1907.

F. X. MATHIS, JR. & L. SIMON.
CATAMENIAL SACK.
APPLICATION FILED JULY 27, 1907.

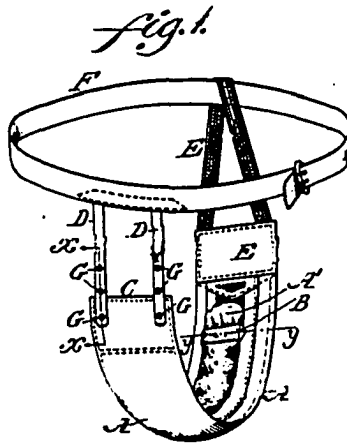

Figure 5.26. Mathis & Simon's "Catamenial Sack" appears to be the same menstrual product offered as the "Venus Protector" (see Figure 5.25).

by "ladies" were procurable. Other advertised sponges included "Ladies' Silk Sponges, very fine, regular form" at \$.20 each; "Selected, with silk netting cover and silk cord," at \$.25 each; "Extra fine, small, medium; ladies' cup shaped silk sponges" at \$.35 each; and "Superfine, large ladies' cup shaped sponges, specially selected forms and shapes" at \$.50 each. Deciphering product descriptions suggests possible contraceptive and menstrual uses for the various types of sponges available. For example, the sponge described as "...with silk netting cover and silk cord" may have been used as a contraceptive sponge or as a reusable menstrual tampon.

Unfortunately, only one page of trusses was available for study, and none were used as menstrual supporters. The page advertising "Protectors, Full Dress" was not included in this edition. The entire pages of corsets were included; there were no attaching devices illustrated on any of the corsets for napkins or receivers. "Diapers" were for infant use.

In addition to commercial menstrual products for sale, components used to fabricate menstrual products were available through mail order: rubber sheeting, safety pins, elastic webbing, hose fasteners, diaper cloth, Turkish toweling, sponges, cotton wadding, and medium to heavy weight "dress goods."

Drug store suppliers continued to wholesale menstrual products during the early twentieth century (Farrell-Beck &

Kidd, 1993). The Bauer & Black Company of Chicago had menstrual products in the catalog of the Kiefer Drug Co. of Indianapolis by 1904. The Bauer & Black name appeared in a patent letter; Otto C. Schulz assigned his patent for an absorbent pad (most probably disposable) to Bauer & Black in 1908 (U.S.P. No. 903,895). An entry in the 1909 catalog of the St. Louis based Meyer Brothers Drug Co. advertised "Dr. Gray's Improved Monthly Friend...the only article on the market that can be washed," for a wholesale price of \$7.50 per dozen (Figure 5.27). The "Monthly Friend" was a menstrual supporter and sack, patented earlier by Albert L. Gray of St. Louis on May 30, 1899 (U.S.P. No. 626,159, Figure 5.28). Other suppliers of belts in the late 1800s and early 1900s were Charles H. Scott & Co. of New York and Chicago, the H.E. Brown & Co. of Chicago, and the Sigsbee Manufacturing Co. of Ayer, Massachusetts (Farrell-Beck & Kidd, 1993).

The J. N. Gardner & Co. of New York placed an advertisement for "Sanitary A & M Serviettes" in the March 10, 1900 issue of *Harper's Bazar* (Figure 5.29). The configuration and materials of the Gardner & Co. Serviettes appeared to be identical in configuration to earlier advertised Serviettes in the Sears, Roebuck catalogs with one difference: a distinctive "A & M" brand with a cross patée (or Iron Cross) logo. I found no information that revealed the meaning of the logo, or if the letters "A & M" referred to a brand name, a company

BANDAGES.

CATAMENEAL.

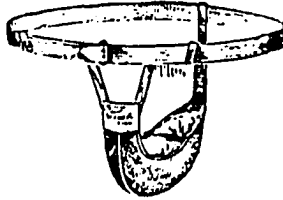

Patented May 30th 1899.

Pouch made of pure gum, trimmed with rubber covered cloth. The only article on the market that can be washed.

Dr. Gray's Improved Monthly Friend..... doz 7 50

Figure 5.27. Advertisement for "Dr. Gray's Improved Monthly Friend" in the Meyer Brothers Drug Co. catalog, St. Louis, Missouri, 1909.

No 626,159.

Patented May 10, 1899

A. L. GRAY.
CATAMENIAL BAG.
(Application filed May 6, 1898.)

(No Model.)

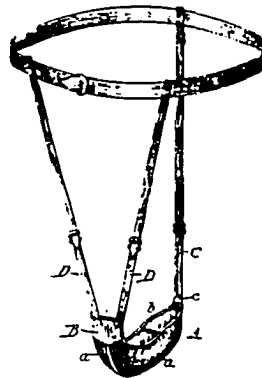

Figure 5.28. The patent drawing for "Dr. Gray's Monthly Friend" (U.S.P. No. 626,159). Some slight modifications were made.



Figure 5.29. Advertisement for "Serviettes" in the March 10, 1900, issue of Harper's Bazaar.



Figure 5.30. This "Hygienic Sanitary Protector" appears to be the former "Venus Protector" (see Figure 5.25). Advertised in the 1908 Sears, Roebuck Catalogue.

name, or merely to product characteristics (i.e., absorbent and medicated). I located no more advertisements for these menstrual pads in subsequent issues of *Harper's Bazar* or in other magazines published in the early 1900s. Rubber companies, such as Canfield, Omo, and Kleinert, advertised dress shields (and eventually, infant rubber pants), but did not refer to any type of menstrual product in their ad copy, not even in a covert fashion. Overall, sanitary protection advertisements disappeared from popular journals after 1900, and did not reappear until the 1920s.

Although menstrual products were not advertised, they were still available. Mail order catalogs like Sears, Roebuck continued to sell menstrual products during the early 1900s. Cohn (1940) referred to an advertisement from the 1905 Sears, Roebuck catalog for "Antiseptic Sanitary Towels" (p. 503-504). In the 1908 Sears, Roebuck catalog, the "Hygienic Sanitary Protector" was advertised (Figure 5.30), evidently the renamed "Venus Protector" (see Figure 5.25). As cited in Busch (in press), the 1917 Sears, Roebuck catalog offered "four types of disposable sanitary napkin, one reusable napkin, four different sanitary belts, one menstrual shield, and eight different sanitary aprons made of rubberized cloth." Menstrual products were also quite steadily advertised by drug supply companies (J. Farrell-Beck, personal communication, January 1994).

Another suggestion that the commercial potential of menstrual products was recognized may be found in the patents. Patent texts revealed that some inventors, like Otto Schulz, assigned their inventions to individuals or to companies. Forty-five menstrual product patents were assigned (see Appendix J); the earliest assignment occurred in 1859 (Clark, U.S.P. No. 23,059). Patents were assigned in the nineteenth century to individuals, i.e., no company names were listed in the patent letters. Twentieth century assignees included corporations and companies. In addition to the Bauer & Black Company, other corporate assignees were the Sanitary Shield & Manufacturing Company, The Borated Specialty Company, the Woman's Mutual Benefit Company, the Standard Mail Order Company, the Junoform Company, the Individual Drinking Cup Company, and The Absorbent Fiber Company (not to be confused with the Absorbent Fibre Company.) Presumably, the assignees intended to manufacture or distribute these items for a profit.

Another method of distribution was also indicated in the patent texts. Two patentees referred to the dispensing of their products from vending machines. Lawrence W. Luellen (1916, U.S.P. No. 1,192,439) created a product that was machine-formed and then individually packaged for vending machines. He assigned his product to the Individual Drinking Cup Company. Elizabeth Sprague (1916, U.S.P. No. 1,195,621)

invented a product that could be sold from coin machines in sleeping cars, toilet and dressing rooms.

Souder in the 1917 **Department Store Merchandise Manuals:**

The Notion Department stated

It has been only within a few years that most of the articles sold in the Notion Department as sanitary goods have been manufactured, but now they are doubtless permanent goods. They may be classified as:

Sanitary aprons and other water-proof articles
 Sanitary belts
 Sanitary napkins (p. 109)

This reinforced Cole's assertion that "the sanitary napkin ...has within recent years become a staple commercial article" (1900, p. 374). The amount of patent activity, especially from 1900 to 1921, suggested the continued interest in the development of menstrual products. Although advertisements for menstrual products disappeared from popular magazines, products continued to be available through department stores, drug stores, and mail order. Certainly the popularity and mass distribution of mail order catalogs, such as Sears, Roebuck, had a tremendous effect on product awareness. How prevalent the use of commercial menstrual products really was is more difficult to discern.

In a recent study, Busch's 1991 questionnaire of 63 women revealed that none of the eight women surveyed who reached menarche from 1900-1919 used either reusable or disposable purchased pads for menstrual management (in press). An earlier questionnaire, distributed by Weideger in 1973,

concentrated on social-psychological information on menstruation, not specifically for information on items used in menstrual management before the twentieth century (Weideger, 1975). In fact, no documented information disclosed that women, before the 1920's, purchased commercial menstrual products. Until further research can be performed using available company sales records, the commercial success of pre-1920 menstrual products still remains a question.

Summary

Information gathered in this investigation suggested commercial menstrual items may have been developed and advertised as early as the mid-1840s. Early menstrual products appear to have been adapted from existing items, such as pessaries, trusses, and suspenders. In the 1870s, advertisements specifically for commercial menstrual products were published in brochures and popular magazines. Early methods of distribution included door-to-door sales by "lady agents" and direct mail order sale from the manufacturer. Mail order houses such as Sears, Roebuck and Montgomery Ward also advertised a variety of menstrual products. By the 1880s, commercial menstrual products were being sold in department, drug, and dry goods stores, and possibly through physicians.

Advertisements for menstrual products in the 1890s often included a sketch of the product. Ad copy was conservative,

employing coded language and euphemistic phrases. A significant number of companies were involved in the manufacture and distribution of menstrual products. After 1900, there is a marked decline in consumer magazine advertisements for commercial menstrual products until the 1920s, although menstrual products continued to be advertised in mail order catalogs and by wholesale drug store suppliers and continued to be sold in department stores. Most literate women by the early 1900s were probably aware of the availability of commercial menstrual products although the volume of actual sales remains unknown. Consumer product awareness of nineteenth and early twentieth century menstrual products may have paved the way for the successful marketing and consumer adoption of menstrual products introduced in the 1920s.

CHAPTER 6

REASONS FOR THE PATENTING OF MENSTRUAL PRODUCTS

The U.S. Patent Office requires a sufficient amount of technological and descriptive information be included in each patent letter, adequately detailed to avoid rejection for "insufficient disclosure" (Gutcho, 1979, p. v). To fulfill this requirement, patentees of menstrual products included detailed descriptions of materials and construction methods necessary to create their products. Inventors also included reasons why their product should be considered as an improvement over earlier products.

I read each patent text and wrote down each reason as stated by the patentee. I found more than 520 reasons given by inventors to support their patents. As I read over the patent texts, I realized the reasons could also be used to discover what women from 1854 to 1921 desired in a menstrual product. The earliest consumer survey discovered to date asking women about menstrual product satisfaction was performed in 1927 (Bullough, 1985). Therefore, scholars know little about what women before 1927 desired in a menstrual product.

In particular, patent texts written by female patentees may help answer this question. Menstrual devices are often considered "uniquely feminine technologies" (Cowan, 1977/1979, p. 31). This suggests that female inventors may have differed

from male inventors in determining what the most desirable characteristics for a menstrual product were.

I found no evidence that female patentees perceived menstrual needs differently from male patentees. Men and women developed all types of menstrual products, with two exceptions. I found no patents granted to men for any type of sanitary apron protector. Men, however, essentially monopolized the patenting of menstrual retentive cups; there was only one female inventor listed, Mildred Coke, who was one-half of a male-female inventor duo (Mallalieu & Coke, 1903, U.S.P. No. 737,258).

The similarities in reasons given by inventors for their products suggested to me that some type of dialogue existed between men and women about menstrual products. Not only were women talking to men, but men were listening to women about menstrual needs.

Upon reading the patent texts, I also discovered that menstrual products were considered by the patentees as improvements over existing products, not original discoveries. Alfred A. Starr, the first U.S. menstrual product patentee, was aware women were already using a form of menstrual management, namely, "to girdle themselves with a tape or string to which the ends of the napkin used to cover the vulva are attached" (Starr, 1854, U.S.P. No. 11,574). Other patent texts suggested that other menstrual devices, some possibly

manufactured, also existed. In a later patent, Charles E. Clark, acknowledged that "I am aware that an article somewhat analogous to my menstrual receiver has been long known and used," as well as having been cognizant of "the receivers of Stark and Segin" (Clark, 1859, U.S.P. No. 23,059). E.L. Perry (1865, U.S.P. No. 49,915) gave the name of a patentee whose invention was rejected by the U.S. Patent Office, Dr. A. Meyers. Later patentees, such as Nanette Amia (1884, U.S.P. No. 296,104), indicated knowledge of concurrently developed menstrual products, in this case, Darius Goff's "fibrous pad" (1883, U.S.P. No. 271,625). The Amia-Goff collaboration could also be considered as an example of female-male dialogue.

Because many of the 520 reasons were similar, I compressed the list into more manageable categories, consisting of three primary and four secondary categories. Primary categories were **comfort, cleanliness, and convenience**; secondary categories were **health, security, cost, and miscellaneous reasons**.

Comfort and fit aspects were major reasons for research and development into improving menstrual products. Inventors attempted to create menstrual products that would not bind or chafe, were lightweight, would not impede active movement or urination, and would adjust and adapt to the wearer during use. From 1906 through 1911, comfort and fit aspects are referred to with greater frequency.

Cleanliness was also a motivation for improving menstrual products. By developing a menstrual product that would prevent leakage, inventors would help the wearer keep her clothing and her bedclothing unsoiled. For reusable menstrual products, cleanliness also included the ease with which the product could be laundered. From the patent texts, references increased after 1900 that addressed the need for a product that would prevent soiling.

Convenience as defined by patentees denoted the ease with which the product could be used. Inventors of menstrual technology desired to create a functional, practical product that was easy to carry, as well as easy to dispose of (if designed for that purpose). The ease and speed of reapplication of the absorbent or pad was also desired in a menstrual product; these characteristics appeared to increase in importance from 1906 through 1911.

Health-related reasons were also motivating factors behind menstrual product development. Such reasons included containment of genito-urinary discharges; the use of the menstrual product as a womb, abdominal, or garment supporter; the use of the menstrual product to keep the vaginal area either warm or cool; and the use of the menstrual product to mask offensive odors. Patents granted from 1901 through 1905 presented the greatest number of health-related reasons for menstrual product improvement.

The cost of the product, including the cost of manufacturing and the cost to the consumer, was more frequently cited by patentees after 1900. Remaining reasons included ease of storage, creation of a product that would abolish the need for existing napkins or cloths, as well as the creation of a renewable or specifically disposable product. (Disposability was referred to in only nine of the patent texts, although many more pads were patented that were designed to be disposed of after use.)

I then reviewed menstrual product advertisements to discover if the reasons listed in the patent texts were used as incentives for customer purchase. From the advertising copy, I wrote down each "selling point" that was given, and then did a hand tally. I found that there was a slightly different emphasis in advertising copy for menstrual products, which placed health first, followed by comfort, cleanliness, and absorbency.

Although the ideal menstrual product would be a combination of all those aspects, health was particularly underscored. Commercial menstrual pads were described as antiseptic, hygienic, sanitary, or aseptic, descriptive words that were synonymous with good health.

Commercial menstrual products also claimed to be more comfortable than home-made products. Commercial pads especially provided freedom from chafing, and purported to be

less bulky than home-made products. Adjustability, especially for menstrual supporters, was also used as a selling point.

Commercial menstrual pads or napkins were advertised as more absorbent than home-made products. A highly absorbent pad would stop menstrual fluid leakage. Apparel and bedclothing could remain free from stains, allowing a women to maintain personal cleanliness during the menstrual period. Another important advertising message was disposability. Disposable pads were claimed to be less expensive than laundering reusable cloths and more convenient for women when traveling. Because they could be thrown away or burnt after use, the unpleasant chore of washing soiled menstrual cloths was eliminated. Menstrual supporters, on the other hand, were advertised because they could be laundered, and, therefore, were more sanitary.

Social messages equating cleanliness with gentility were also conveyed in advertisements for menstrual products. This was a commonly used advertising ploy directed at the late nineteenth and early twentieth century middle-class consumer, who had been indoctrinated into the "culture of cleanliness" (Bushman & Bushman, 1988). The 1900 ad in *Harper's Bazar* for "Serviettes" inferred that their "sanitary and healthful properties make it appeal to every well-bred woman." Health and cleanliness during the menstrual period, then, became equated with breeding and refinement.

The reasons listed by patentees also revealed the difficulties associated with the development of menstrual products. Persistent references to such aspects as comfort, fit and cleanliness suggested that patentees never completely succeeded in creating the ideal menstrual product. According to the patent texts, menstrual products sagged and bagged, interfered with urination, and often chafed the wearer. Failure of menstrual products was not just physically uncomfortable, but was embarrassing as well. Patent texts referred to probable real-life predicaments such as the accidental detachment of the napkin from the belt (Luzzi, 1904, U.S.P. No. 774,191; Potter, 1916, U.S.P. No. 1,192,683) and the leakage of menstrual fluid down the leg (Everson, 1899, U.S.P. No. 623,658). Other texts suggested that some women experienced real health risks using early menstrual products. An india-rubber catamenial sack with inflated edge "bolsters" for cushioning next to the vaginal area was the subject of Andrew Baum's 1868 patent (U.S.P. No. 78,414). His sack was an improvement over previous "defective" products because the "gum" on previous bolsters

...becomes heated by contact with the person, and the double edges of the flat sack are thus weakened, and give way easily, while the same cause immediately destroys the inflated cushions by the expansion of the air within, which bursts and escapes, thus in both cases rendering the sacks unserviceable, and exposing the wearer to unpleasant accidents.

Vaginally-inserted menstrual retentive devices also presented their own unique problems. Philip W. Dautrich (1895, U.S.P. No. 535,980) contended that his menstrual product was an improvement over previous retentive devices because "...the ring or seat [to be inserted into the vagina] is preferably secured permanently to the upper end of the tube forming the body of the sack...and therefore the liability of separation of the parts is reduced to a minimum." Jacob R. Lang's "Menstrual Receptacle and Uterine Supporter" (1901, U.S.P. No. 679,478) was specified to be constructed

...preferably of hard rubber...the best material known to me for the purpose, since it does not rust and will receive and retain a smoothly-polished surface. It is insoluble in the liquids of the body, is a poor conductor of heat and cold, and at the same time is light and stiff and can be molded into any desired form...

Product failure interpreted from patent texts may also provide clues as to why commercial menstrual products before 1920 appeared to have had limited consumer success. The types of products that were available may simply have been unable to live up to their claims. Although the dearth of advertisements for commercial menstrual products in early twentieth century magazines has often been attributed to the social taboos that surrounded the promotion of such products, the basic failure of commercial menstrual products may also account for lack of promotion. Some women's magazines, such as *Good Housekeeping*, may not have wanted to endorse products

that would have provided their readership with little or no success in product performance.

Summary

From the patent texts, major reasons for continued research and development of menstrual products were comfort, cleanliness, and convenience. Patentees continually attempted to improve existing menstrual products. Reasons for continued research may also be interpreted as points of failure of menstrual products patented from 1854 through 1921.

Advertising copy for menstrual products differed slightly from the reasons listed in patent texts for improving menstrual products. Menstrual products were advertised emphasizing aspects of health, comfort, cleanliness, and absorbency. By the twentieth century, advertising copy suggested that the use of commercial menstrual products was a sign of good breeding.

CHAPTER 7

MENSTRUAL TECHNOLOGY AND WOMEN'S DRESS

Menstrual Products and Fashion Changes

The role commercial sanitary protection products played in the history of fashion change has been a point of interest to many scholars. In general, scholars agree that the development of disposable sanitary protection was one of many variables that affected fashion changes. Schroeder (1976) suggested the rapid changes in women's fashions in the United States in the early twentieth century were "the outward expressions of inner confidence, something that was surely augmented by the development of cheap, absorbent and disposable menstrual products" (p. 107-108). He further attempted to correlate the adoption of disposable sanitary pads with the shortening and lightening of skirts, and suggested one of the reasons for the persistence of long skirted fashions was the absence of reliable sanitary protection. Payne, Winakor, and Farrell-Beck (1992) implied increased public acceptance of revealing fashions during the 1920s and 1930s may have been spurred by the development of the sanitary napkin and tampon. Another scholar, reviewing fashion changes in the twentieth century before World War I, questioned any cause or effect relationship between the adoption of the commercial disposable napkin and women's fashion changes. Busch (in press) concluded there did not

appear to be a cause and effect relationship between the two phenomena, and stated the trend towards "lighter, more revealing clothing seems to have occurred despite rather than because of sanitary napkins."

There is some validity in all of these opinions. I believe there was a relationship between commercial sanitary protection products and changes in fashion. But, after reading all the available literature on menstrual management devices and reading all the patent texts, I suggest that the relationship between menstrual products and fashion change may have been viewed the wrong way around. Perhaps the changes in women's dress influenced the design of menstrual products more than menstrual products affected changes in women's dress.

During the mid-1850s, when the patenting of menstrual products began, the fashion silhouette was bell-shaped, held out by petticoats and (later) hoops. Bulkiness of a menstrual product below the waist area would have been disguised. Size of the supporter would not have to be a major design consideration and menstrual supporters and belts could be as big as was deemed necessary. As the fashion changed and bustles became popular the lower torso area was still swathed in yards of material. Certainly a menstrual supporter or belt would need to be relatively flat across the abdominal region, but could have a significant amount of fullness in the back that would be masked by the bustle. Although a snug fit was a

requirement in menstrual receiver or absorbent design, snugness was directed towards the vaginal area, in order to catch all the menstrual discharge and prevent leakage, rather than to conceal any tell-tale bulges that may have disturbed the line of the outer garments.

By the 1890s, the bustle had disappeared, and women's skirts became cone-shaped, with a smooth and snug fit at the hip area. The close fit of the skirt at the hip area meant that menstrual supporters and receivers would also have to reduce their bulk as well. In the patent texts, however, reduction in bulk or snugness of fit is not mentioned in relation to fashion until after 1900, when menstrual products were designed that permitted women to wear "delicate, flimsy" clothes (James & Kippen, 1902, U.S.P. No. 709,223) and were "not calculated to destroy the wearer's shape or set of her clothes" (Coleman & Jarmulowsky, 1905, U.S.P. No. 780,598). This suggested to me that the fashion had changed first, precipitating the change in menstrual product design. (Appendix K is a listing of some patents that referred to the development of a menstrual product as it effected the fashion silhouette.)

I began to consider a possible relationship between styles in women's underdrawers and menstrual product design while working with the Iowa State University Historic Costume Collection. I had observed that women's underdrawers from the

nineteenth century were open in the crotch area. Further research revealed that this was the prevailing style in women's underdrawers in the nineteenth century (Cunnington & Cunnington, 1951/1981; Ewing, 1978; Saint-Laurent; 1966.)

I could find no information that explained why underdrawers were open-crotched. (Such information is curiously absent from lingerie histories.) Certainly the logic of such a style is fairly obvious. The number of layers of inner and outer garments must have made for some interesting maneuvers in the water closet or outdoor privy. Open-crotched drawers would have greatly facilitated performing basic bodily functions and allowed ventilation. Open-crotched underdrawers would also have made the changing of the menstrual cloth or napkin easier, and also gave the menstruating women a choice: the menstrual supporter or belt could have conceivably been worn outside the drawers or inside the drawers next to the body.

The prevalence of the open-crotch style in drawers may have complemented the trough- or canoe-shaped catamenial sack, which was the principal design of the menstrual receiver until 1900. When in use, the receiver would have hung down between the wearer's thighs. Open-crotch drawers would have allowed for this. I am not making a claim that open-crotched drawers were primarily worn because of their role in menstrual management; I found no information that indicated there was

any relationship between the two. But menstrual management was probably a bit easier with open-crotch drawers.

The open-crotch style was the most commonly worn style in women's underdrawers until the 1880s (Cunnington, 1951/1981). Closed-crotch styles were worn as early as 1874, but did not seriously challenge the open-crotch styles until the 1890s. By 1908, the prevailing style in underdrawers was the closed-crotch style, although both styles co-existed until the 1920s (Cunnington, 1951/1981; Ewing, 1978). I could find no definitive reason for the replacement of the open-crotch style with the closed-crotch style. One plausible explanation may be health-related. Physicians, such as Dr. Marion Craig Patten, advised women "that the most hygienic underclothing for women should be closed, as the long sweeping skirts easily throw the germs onto the body" (Patten, 1909-1910, p. 387).

Earlier, I documented the change in menstrual receiver design from the canoe-shape to a flat rectangular shape. The gradual change to the flat menstrual receiver may be related to the adoption of closed-crotch underdrawers. Canoe-shaped receivers may not have fit comfortably under closed-crotch drawers, thereby creating a need for flat menstrual receivers.

The closed-crotch undergarment may also have encouraged the efforts of some inventors of menstrual products to eliminate the separate menstrual carrier and concentrate on merging the carrier and absorbent into one unit. The sewn

crotch of the undergarment could have served as a support for the menstrual napkin. However, the number of napkin-holders that continued to be developed after closed-crotched undergarments were available suggested the real did not meet the ideal.

Menstrual Products and Reform Movements

The nineteenth century is often characterized as an era of reforms. Many reforms were centered on improving health, through diet or exercise. One type of health reform was the dress reform movement. As the century wore on, more and more people believed that health and dress were closely related. Advocates of dress reform condemned such fashion practices as corseting, heavy skirts, tight sleeves, and veils (Ecob, 1892; Napheys, 1870; Williams, 1890). I searched writings of dress reform advocates, and attempted to discover if menstrual products were included as a part of dress reform.

I found no written documentation that indicated dress reform also included menstrual product research and development. I did find a study that examined the relationship between menstruation and dress among college women between 1890 and 1920. Dr. Clelia Mosher (1927) reported that she found

An extraordinarily close correlation...between the fashion of dress and the menstrual condition of women. As the skirt grew shorter, narrower, and lighter in weight, and the waist grew larger, the functional health of women improved. This narrowing and shortening, which are advantageous to the health of women, of course do not

include such vagaries of fashion as the excessively narrow skirt... (Mosher, 1927, p. 27)

Mosher did not mention any role that menstrual products may have played in the lives of the women in her study.

I did find evidence that suggested some dress reform advocates may have considered menstrual products as part of their program. One menstrual product patentee, Mrs. Annie Jenness-Miller, traveled the nation giving lectures on "Artistic and Healthful Dress" to women and men. According to Macdonald (1992), Jenness-Miller used live models to display health garments; during these live demonstrations, the men in the audiences were asked to leave. Perhaps Mrs. Jenness-Miller used these opportunities to advertise her "Perfect Suspensory Band."

Other advocates of healthful dress reform included members of The Ladies' Physiological Institute of Boston and Vicinity (Verbrugge, 1979), the Women's Christian Temperance Union (Blocker, 1989; Bordin, 1981/1990), the Water-Cure movement (Donegan, 1986; Shew, 1851), and "Ladies' Physiological Societies" (Ehrenreich & English, 1978, p. 45). Through lectures and classes, women were encouraged to take an active role in improving their health. Because menstruation was part of a woman's total health, surely menstrual difficulties and therapies were discussed, if not in formal lectures, then informally, woman-to-woman. However, I found no conclusive evidence that demonstrated that menstrual

management was lectured on by health and dress reform advocates.

Summary

A comparison between menstrual product design progression (using menstrual patent illustrations) and women's fashions from 1854 through 1921 did not reveal that commercial sanitary protection products directly caused changes in women's fashions. From the patent texts and drawings, it appeared that changes in women's fashions may have acted as the impetus for changes in the design of menstrual products, ultimately influencing menstrual product evolution from 1854 through 1921.

No hard evidence has been uncovered that placed the research and development of menstrual products into health and dress reform movements. However, some dress reform advocates may have provided information on menstrual products during lectures and classes on menstruation and menstrual health.

CHAPTER 8

MENSTRUAL PRODUCTS AND THE WORKING WOMAN

I attempted to locate scientific inquiries or occupational health literature that established any relationships between manual labor and menstrual difficulties. I discovered that few studies examining this relationship were performed before 1921. However, numerous male physicians examined the relationship and effect between menstruation and higher education.

Probably the most famous exploration into this relationship was performed in 1873 by Dr. Edward Clarke. In *Sex in Education; or A Fair Chance for Girls*, Clarke argued that a woman's education should "be guided by the divine rights of her system" (1873, p. 45). Especially opposed to co-education, Clarke was convinced that it created all sorts of menstrual difficulties and that "it emasculates boys, stunts girls; makes semi-eunuchs of one sex and agenes of the other" (1873, p. 129). Although the main thesis of his book was the causal relationship between education and increased menstrual difficulties, Clarke briefly addressed working women, or "female operatives" (p. 131). Clarke alleged "female operatives of all sorts are likely to suffer less, and actually suffer less, from persistent work than female students,...because the former work their brains less" (p. 131). Therefore, in his opinion, women should continue doing

factory and manual work during their menstrual periods without a week of rest, although inactivity for female students during the "catamenial week" (p. 37) was essential.

Clarke's opinions on the debilitating effects of menstruation on women were not shared by everyone. Julia Ward Howe collected a series of essays by women and men to refute Clarke and his position against higher education for women. Howe (1874/1972) argued "boys as well as girls break down under severe study, men as well as women, and at least as often" so it might be wise to "let a milder and more human regime be devised and enforced" for the good of all students, regardless of sex (p. 9).

Many of the contributors to Howe's book used Clarke's statement on "female operatives" as justification for women being allowed to be co-educated with men in colleges. Maria A. Elmore (Howe, 1874/1972) contended Dr. Clarke "talks as though women in every thing but college life had perfect liberty to change at will their position from the erect to the reclining...as though a regular, sustained, and uninterrupted course of work was something of which they have never had any experience" (p. 174). Elmore listed many jobs or "regimens" (p. 174) that did not excuse women from work "every fourth week" (p. 175), such as factory labor, clerking, tailoring, dressmaking, teaching, and marriage (managing a home), and wanted to know why colleges should pay such close attention to

a woman's "physiological nature" if other institutions "overlook it entirely" (p. 182). Neither Elmore or any of the other essayists suggested that complete rest be required of college or working women during menstruation.

In the same year Howe's book was published, a public inquiry into the relationship between work and menstruation was being done by Dr. Azel Ames, who was a Special Commissioner of Investigation to the Massachusetts Bureau of Labor Statistics. He published his findings and conclusions in *Sex in Industry: A Plea for the Working Girl* in 1875 (cited in Harlow, 1986). Ames described the tasks performed by women laborers in six trades: typesetting, telegraphy, counting money, counting rattans, basketmaking, and sewing with foot-powered machines. He detailed the physical and mental abilities necessary to perform tasks in these tasks, and gathered reports from supervisors, employers, and physicians on the types and magnitude of menstrual problems experienced by the female workers. (Harlow did not indicate if Ames interviewed the actual female workers in these trades.) Because these trades demanded simultaneous physical and mental activities, he concluded that energy was being drained away from the reproductive organs, which would result in menstrual dysfunction. Because Ames believed there was a causal association between industrial labor and menstrual disorders in women, he recommended limiting women's employment

in industry (Harlow, 1986, pp. 40-41). Whether his recommendation to limit women's employment in the labor force was entirely altruistic is debatable. As Harlow observed, Ames' analysis of the relationship between work and menstruation was based on the assumption of the frailty of women, as well as anecdotal (and possibly second-hand) evidence of menstrual dysfunction (p. 41).

One woman physician did not accept Ames' and Clarke's belief in the need for extra rest during menstruation. Dr. Mary Putnam-Jacobi investigated the need for rest during menstruation and published her findings in 1877. She argued against forbidding women to work or study during menstruation, and concluded "there is nothing in the nature of menstruation to imply the necessity, or even the desirability, of rest, for women whose nutrition is really normal" (1877/1978, p. 227). J. H. Kellogg, in *Plain Facts for Old and Young*, agreed poor nutrition contributed to ill-health during menstruation and believed women workers should be given some rest during their menstrual period. Kellogg maintained

In many cases, too, they are compelled to remain upon their feet all day behind a counter, or at a work table, even at periods when a recumbent position is actually demanded by nature. There should be less delicacy in relation to the subject on the part of young women, and more consideration on the part of employers (Kellogg, 1882, cited in Bullough & Voght, 1973, p. 74)

I could find no other references to menstrual disability and work, and no references about menstrual products and

working women. According to Harlow (1986), no statistics on gynecological illness in industry appeared until after 1921.

Regardless of the debate over the potential health risk during menstruation, the number of women who entered colleges and the labor force increased steadily from 1854 through 1921. (Unfortunately, statistics of women in the labor force do not include working women doing piecework or homework.) Although many jobs were stereotyped by sex, the 1900 census reported that of the 303 occupations listed, women were found in 295 of them (Rothman, 1978). Typically, women who were in college or who worked outside the home were young unmarried women (Van Horn, 1988), and most likely menstruated regularly. Yet it appeared no consumer survey or analysis was performed before the 1920s on the need for menstrual products.

The first consumer analysis and survey for menstrual products that has been discovered to date was Lillian Gilbreth's sanitary napkin survey done for Johnson and Johnson, issued on January 1, 1927. Vern Bullough condensed the 134 page document, which was brought to his attention by Martha Trescott (Bullough, 1985, pp. 615-627). Although Gilbreth's survey was performed after 1921, I felt that an examination of her findings could be useful when compared to findings I discovered from the patent texts.

Gilbreth took her sample from 1,037 subjects geographically located from Massachusetts to North Dakota.

The majority of those surveyed were college students, but her sample did include one group of high school students (from Detroit), and some business and professional women. Gilbreth calculated that only 16% of those surveyed were satisfied with commercial menstrual products. Nonetheless, even though unsatisfied, women continued to use commercial products. From the subjects' responses, she concluded that women were more likely to make their own napkins if they lived at home, but, once away from home, started using commercial napkins. Limitations of living space, time, and materials were factors in the adoption of commercial products. Gilbreth concluded that the influence of "older associates" at college or work meant that "imitation as well as necessity [became] a factor in developing the use of the commercial napkin" (Gilbreth, 1927, as cited in Bullough, 1985, p. 618).

Gilbreth asked her subjects to list desirable characteristics for a sanitary napkin. The five most important (in descending order) were comfort, adequate protection, inconspicuousness, disposability, and availability. For a sanitary belt, the chief requirements were comfort, inconspicuousness, and launderability. Those surveyed generally used safety pins to attach the napkin to the belt, and preferred a belt that could be slipped on over the head. Other catamenial appliances, such as sanitary aprons and "rubber bloomers" were not popular with those

surveyed, and were considered hot, cumbersome, and unhealthy (Gilbreth, 1927, as cited in Bullough, 1985, p. 625).

Comparing Gilbreth's findings with the categories of desired characteristics for menstrual products listed in the patent texts, comfort heads both lists. All of Gilbreth's desired characteristics were mentioned in patent texts, with the exception of availability. To Gilbreth's subjects, availability meant an accessible store location and the ease in which the customer could purchase menstrual products, whether in person or over the telephone. Embarrassment when purchasing menstrual products from male sales clerks did not appear to be a significant factor inhibiting purchase if the store was conveniently located, and the product was readily accessible.

By 1927, disposable menstrual pads were more popular than reusable pads; Gilbreth stated that the idea of laundering a menstrual napkin was a "distasteful" one to most women (cited in Bullough, 1985, p. 620). But, she suggested the idea of a totally flushable napkin be eliminated, since napkins tended to clog the plumbing systems. The edited version of Gilbreth's study did not indicate that health factors were involved in commercial napkin use, unlike the late nineteenth century menstrual product advertisements.

From Gilbreth's survey, it appeared the same type of product failures continued to beset commercial sanitary

menstrual products. She concluded that women who made their own menstrual products believed the homemade products were more comfortable and fit better. But, even though the products were not completely successful, Gilbreth did not expect that the commercial menstrual pad would disappear from the market.

There is no information from Bullough's condensation of Gilbreth's report that explained the methods or rationale underlying subject selection. Perhaps economic assumptions played a role. College and professional women may have been considered the most likely group of women to have the economic resources to purchase commercial products. There may have also been an assumption that college and professional women were better informed on current products. Also, since Gilbreth was a college-educated, professional woman, she may have been best acquainted with the personal habits of her reference group. Since it appeared that Johnson and Johnson implemented most of Gilbreth's recommendations for improving sanitary protection products (Bullough, 1985), college-educated, professional women may have played a significant role in the creation of a more functional menstrual product, as well as forming the first consumer group to adopt these products on a widespread basis.

Summary

In the nineteenth and early twentieth centuries, most male medical authorities considered higher education for women to be a causal factor in increased menstrual disability. As a result, women were repeatedly cautioned against pursuing higher education, especially co-education. However, medical authorities were less likely to extend the same kind of caution to women who did factory labor.

Although the number of women who entered the labor force in the United States increased steadily from 1854 to 1921, no information written during that time indicated that commercial menstrual products made life easier for the working woman in factory or labor-intensive jobs. A survey published by Lillian Gilbreth in 1927 suggested that commercial sanitary products did make menstrual management easier for collegiate women, and business and professional women.

CHAPTER 9

MEDICAL PRACTITIONERS AND MENSTRUAL TECHNOLOGY

The role that World War I French Army nurses played in the menstrual product industry has been well documented. French Army nurses in World War I utilized surgical dressings of cellulose wadding as menstrual pads. After the war, the Kimberly-Clark Corporation, the manufacturer of the wadding, was left with a surplus of these bandages. Capitalizing on the nurses' inventiveness, Kimberly-Clark developed the Kotex® pad.

The role of nurses in the menstrual product business did not end after the war. In 1920s advertisements, nurses were frequently used to endorse menstrual products. The use of nurses may have given the impression that the medical community recommended their use.

I discovered that distributors and manufacturers of commercial menstrual products in the nineteenth century also used endorsements from the medical community as a way to promote use of commercial products. Examples included the "Woman's Perfect Suspensory Band...pronounced perfect by physicians" (see Chapter 5, Figure 5.6a); "Spungia Napkins...endorsed by leading physicians" (see Chapter 5, Figure 5.14); and "Serviettes...recommended by the medical profession" (see Chapter 5, Figure 5.24). Unlike sanitary pad advertisements from the 1920s, advertisements in the 1800s

were more likely to feature physicians, rather than female nurses, as endorsers of menstrual products. This may, in part, reflect nineteenth century gender bias, as well as public and professional ambivalence about the competence of the nursing profession in general.

A judgement of the sex of the endorsing physician must be carefully made. Although male physicians outnumbered female physicians from 1854 through 1921, the number of female physicians increased dramatically, from 200 or less in 1860 to over 7,000 by 1900 (Barlow & Powell, 1981/1984). Many female physicians were employed by women's colleges, and played an important role in educating women about health (Rothman, 1978). So, the endorsing physician could have been a woman.

Another issue to ponder is the implied meaning of the terms "physician" and "the medical profession" especially in the nineteenth century. The ranks of nineteenth century physicians included the licensed and unlicensed, orthodox and sectarian, schooled and unschooled. The label "Doctor" was quite freely used in advertising consumer health products, especially patent medicines and therapeutic devices. Because there was no agency that regulated medical claims, endorsement by a member of the medical profession may not have been a discerning advertising ploy for nineteenth century menstrual products. During the twentieth century, a change in attitude about medical endorsements in advertising occurred. As the

orthodox medical profession started the consolidation of its authority and control in 1900 (Starr, 1982), endorsement of a drug, therapy, or product by a member of the (orthodox) medical professional became a more respected advertising strategy.

As I read the patents, I observed that only two patentees identified themselves as "M.D." None identified themselves as nurses or as belonging to any medical profession. Two patentees who also advertised their menstrual products were "Dr." in the advertisement, but not in the patent text: Hiram Farr (1884, U.S.P. No. 300,770) and Albert Gray (1899, U.S.P. No. 626,159). When Hiram Farr advertised his patented "Menstrual Receptacle No. 1" he referred to himself as "Dr. H.G. Farr" (see Chapter 5, Figure 5.2). Albert Gray's menstrual product was later sold as "Dr. Gray's Monthly Friend" (see Chapter 5, Figure 5.27). In the patent texts, there are no indications that Farr and Gray were physicians.

Although the role of physicians in the research and development of commercial menstrual products is unclear, advertisements discovered in pharmaceutical catalogs suggested that physicians may have acted as distributors of menstrual products. They may have purchased menstrual products from wholesalers and then sold them to female patients. Working with drug stores, physicians may have also "prescribed" menstrual products as a therapeutic device. Because most

nineteenth and early twentieth century mainstream medical professionals considered menstruation a pathological, debilitating condition of the reproductive system, commercial menstrual products may have been considered more appropriate if prescribed as a therapy, rather than for regular use.

Summary

The medical profession played a role in the development and adoption of commercial menstrual products, but the true extent of that role needs further study. In the nineteenth century, it appeared that physicians were the most likely "medical authorities" to endorse menstrual products; in the twentieth century, female nurses were most frequently used. Although some physicians patented menstrual products, no other written documentation was uncovered that proved doctors worked with menstrual product inventors to develop safe, functional menstrual products.

CHAPTER 10

SUMMARY AND CONCLUSIONS

Summary

In the nineteenth and early twentieth centuries, most mainstream medical professionals considered menstruation a pathological, debilitating condition of the reproductive system that excluded women from any strenuous mental activity. Yet, no findings from my research revealed that products were being developed by medical practitioners specifically for use during menstruation as a treatment for this pathological condition. What women really thought of menstruation or the difficulties that they experienced managing it still remains unknown.

Menstrual management in the United States before the late nineteenth century consisted of homemade menstrual belts and napkins. Some were rags or folded pieces of cloth; others, although homemade, were more sophisticated in design. Typically, these products were washed and reused. In 1854 the first United States patent was granted for a menstrual product. The number of patents and the continuous patenting activity of menstrual products from 1854 through 1921 indicate that there was a growing perception that homemade menstrual protection was inadequate, as well as a realization of the commercial potential of such products.

There were 185 patents discovered for menstrual products granted from 1854 to 1921 by the United States Patent Office. Patenting activity involved 171 different people: 101 men, 66 women, and 4 persons of unknown sex. The typical patentee was a man, who lived in a metropolitan area of the Northeast region of the United States. Although the majority of menstrual product patentees were men, a considerable number were women.

The types of menstrual products patented from 1854 to 1921 included (1) the belt or supporter, (2) the catamenial sack or menstrual receiver, (3) the absorbent, (4) attaching devices used in catamenial products, (5) catamenial garments or appliances, and (6) vaginally inserted menstrual retentive cups. In the United States, tampons were not patented as menstrual products, but were considered surgical dressings or bandages.

In general, menstrual products became progressively simpler in design and construction. Eventually, the menstrual receiver or napkin-holder and the menstrual absorbent merged into one unit, a sanitary napkin with a waterproof layer that prevented leakage. A number of different absorbent materials were used to create an all-in-one sanitary napkin, the majority of which were disposable. Disposability was not a main patenting motivation from 1854 to 1921, but was emphasized in advertisements for commercial menstrual pads.

From the patent texts and the advertisements, comfort, convenience, and cleanliness appeared to be major reasons given why women should use commercial menstrual products.

Menstrual products were available through a number of different sources: door-to-door saleswomen, mail order, drug stores, and department stores. Advertising copy was discreet, but ads were frequently accompanied by line drawings of the products. Information about menstrual products may also have circulated through lectures and classes offered by health and dress reform advocates, as well as by such organizations as the Women's Christian Temperance Union and physiological societies. After 1900, the number of ads for menstrual products disappeared. Patent activity, however, increased: almost twice as many patents were granted for menstrual products from 1900 to 1921, as from 1854 to 1899.

The growing number of women in the labor force might have been one factor that promoted the use of commercial products. However, no evidence to support this supposition has been discovered. Although female nurses played a pivotal role in the creation of the 1920s sanitary napkin, I found nothing that linked the nineteenth century medical profession to the creation of menstrual products from 1854 to 1921.

Commercial menstrual products were not the direct cause of any radical fashion change, although they may have played a role in fashion adoption. Changes in women's clothing more

probably affected the design and shape of the menstrual supporters and receivers.

Conclusions

In conclusion, I will review and answer the research questions that were presented in Chapter 1, using the findings from my research.

Starting in the mid-nineteenth century, there was a gradual change in the perceptions of the kinds of products considered appropriate in satisfying menstrual needs. The lack of advertisements or patents of menstrual products before the 1850s suggested that most menstrual products used by women were homemade. Past research done by scholars also supported this, as did the discovery of the homemade sanitary pad and supporter in the Valentine collection. The first menstrual product patent was granted in the United States in 1854, marking the beginning of the commercial sanitary protection industry in this country.

The number of menstrual patents granted from 1854 to 1921 suggest that a change in the perception of menstrual needs occurred: that homemade products women developed for menstrual use were not considered as adequate.

It still remains unknown how satisfactory homemade menstrual products were. According to Gilbreth's 1927 survey (Bullough, 1985), women considered home-made products more comfortable and absorbent than commercial products.

Regardless of comfort, women used commercial products because they were cheaper, easier to obtain, carry, and dispose of, not necessarily because they performed better in actual use. This would seem to indicate that commercial products became popular because women's lifestyles were changing, not because basic menstrual needs were changing.

From the patents and other sources, I established no direct link between women working outside the home and commercial sanitary protection's development or adoption from 1854 to 1921. There are certain facts, however, that imply there was a relationship between these factors. The number of women who were employed outside the home increased steadily throughout this time, especially after 1900. Patenting activity increased similarly. More women in the work force would certainly increase the demand for dependable menstrual products, as well as broaden the consumer population who could afford such products.

The expanding mobility of women was another factor that may have spurred menstrual product development. Some patent texts suggested that commercial menstrual products were very useful when traveling. Advertisements for commercial menstrual products also used this as a selling point. The patent texts also implied that women were becoming more active in general, and that walking and bicycling during the menstrual period were facilitated by using commercial

menstrual products. There was no indication from male or female patentees that menstruation was necessarily debilitating. Women did not have to spend the menstrual week resting or lying down and could pursue normal activities during menstruation.

The role of the medical profession in the development of commercial menstrual products still remains unknown, although members of the medical professions endorsed those products in advertisements. The role that female nurses played in the development and adoption of menstrual products after World War I has been well established. However, the precise function that physicians (either male or female) played in the development of menstrual products is unclear. An interesting observation must be noted: I found no medical warnings given by physicians against the use of menstrual devices or products from 1854 through 1921.

Besides physicians and nurses, other medical professionals were also involved in menstrual product distribution. Information discovered by Jane Farrell-Beck (1994) suggests that druggists and pharmaceutical supply houses may have been major suppliers of commercial menstrual products, especially from 1900 to 1920. Menstrual products were continuously offered through these sources. Following the law of supply and demand, it is not likely that menstrual products would have continued to have been sold if the demand

was not there.

Nineteenth century commercial menstrual products were presented to the public through the popular media of the era. Women learned about menstrual products through discreet advertisements placed in magazines and newspapers. Another way menstrual products were presented to the public was through door-to-door sales. Information on menstrual products may have been circulated through lectures on physical hygiene and health, as well as by the "female underground" (Schroeder, 1976, p. 107) that disseminated intimate information before 1920.

After 1900, advertisements for menstrual products disappeared from popular magazines. Yet the patenting activity from 1900 to 1921 increased. I found no information that satisfactorily explained this incongruity.

Commercial menstrual products do not appear to have been the direct cause of any major fashion changes in women's dress from 1854 to 1921. Changes in women's fashions appeared to have affected the design and construction of menstrual products, however. As women's clothing became lighter and less bulky, commercial menstrual products reduced their size as well.

Perhaps the most significant effect menstrual products had on women's clothing was that improved products may have helped to foster certain changes, as suggested by Payne et al.

(1992). The question, remains, however, whether menstrual products really were "improved" and if women really did feel that they could wear certain clothing because of improved protection.

**Implications of this Study and
Recommendations for Further Research**

The role of women in menstrual technology The number of women that were granted patents for menstrual technology from 1854 to 1921 is an important finding of this study. It would appear that menstrual products afforded many women the chance to enter the male-dominated realm of patent registration. Female involvement in patenting menstrual products may represent the greatest involvement by women in any product class. More extensive research into the total number of all women patentees from all product classes needs to be performed before such a conclusion can be drawn, however. Patenting activity after 1921 needs to be examined to discover if the full involvement of women in patenting menstrual products continued throughout the twentieth century.

The role of men in menstrual technology My research established that the majority of menstrual product patentees from 1854 through 1921 were men. Further research needs to be performed to discover if this represents male dominance or male-female cooperation. It would be interesting to learn how male patentees learned about menstrual difficulties and needs; certainly, women played a significant role in the sharing of

that type of information with men.

The apparent male domination of menstrual technology may have been another segment of the male takeover of female reproductive medicine (like midwifery). Further research into this facet of menstrual technology needs to be done before any definite conclusions can be drawn.

The commercial aspect of menstrual technology Although sanitary protection has become a profitable business since the 1920s, not much is known about the commercial aspects of this industry from 1854 to 1921. The vigorous patenting activity and the number of assigned patents suggest that the commercial potential of menstrual products was recognized early in the history of sanitary protection products. Now that the names of some of the companies involved in manufacturing or marketing menstrual products are known, further research into company histories may reveal more information on distribution and commercial success--or failure.

Social factors and menstrual technology For centuries, women had been using homemade products, presumably with reasonable success and satisfaction, changing and adapting these items as needed. In the nineteenth century, patent texts, then advertisements, insinuated that homemade products were no longer satisfactory, and that no "well-bred" woman would be without commercial products. The motivating social-psychological factors behind the rejection of homemade

products and the endorsement of commercial products may provide extra insight into the ultimate success of commercial menstrual products.

Menstrual products and the failure of available technologies An aspect of menstrual products that needs further investigation is an evaluation of product failure. Although I discovered that menstrual product inventors utilized current technologies and materials in creating menstrual products, I found no indication that those technologies resulted in a successful product. In fact, because so many product developers were ambiguous in their descriptions of materials ("any suitable material," "any suitable absorbent"), this suggested to me that early menstrual product development was hampered because, although the idea was there, the technology wasn't. For example, although the use of vulcanized rubber to create rubber cloth did indeed produce a waterproof fabric, this fabric was uncomfortable when worn. This is evident in Gilbreth's statements about "rubber bloomers" and sanitary apron protectors (cited in Bullough, 1985). Gilbreth stated these products were unpopular with her subjects because they were hot and uncomfortable, no doubt because they did not allow adequate ventilation. Another example of technology failure was the devices used to secure the napkin or napkin-holder to the menstrual belt. Even though numerous attaching devices

had been designed, and many modifications to the regular safety pin had been conceived, women still preferred to use two regular safety pins to attach the napkins to the belt in 1927, according to Gilbreth (cited in Bullough, 1985). The unenthusiastic consumer adoption of commercial menstrual products until 1921 may be related to overall product failure, due, in large part, to the failure of available technology.

Menstrual products and the adoption of new technologies

Along with the effect that failed technology had on menstrual products, the effect of new technologies also needs to be further examined. In particular, the types of materials used in menstrual absorbents needs to be fully examined.

Although the most commonly mentioned absorbents listed in the patents from 1854 to 1921 were sponges and raw cotton, it was wood fiber wadding that was used for the Kotex® sanitary napkin (Stanley, 1993). Wood fiber was purported to be more absorbent than previous materials. Wood fibers were also mentioned in menstrual product patents, and were referred to as wood wool, excelsior, or wood fibers. I also searched the patents for any reference that might have indicated that viscose rayon fibers might have been used as a menstrual absorbent. I found no connection in any of the patents between sanitary napkins and viscose rayon.

The development of more dependable elastic webbings may also have helped in the development of a more reliable

product. Likewise, machinery that was adapted for use in menstrual product manufacture needs to be researched. It is quite possible that the design change from a trough-shaped menstrual product to a flat rectangular product made mass-production and packaging easier and less expensive, contributing to eventual consumer acceptance.

Epilogue

Throughout time, the basic performance requirements for sanitary protection products have not changed: to effectively and efficiently absorb and retain the menstrual discharge, to be comfortable when doing so, and to not disturb the outline of the clothes. Whether home-made or commercial, menstrual products were expected to adhere to those requirements. It appears, however, that menstrual products have never been entirely successful in fulfilling those requirements.

It also appears that the basic configuration of the sanitary pad has not significantly altered since the 1920s. During my library search, I discovered a compilation of menstrual products patented in the United States from January 1975 through 1978. Gutcho (1979) based her report on the patents that had been issued for these products. Although she did not include the entire texts of the patents, she did include pictures and detailed descriptions of the products. To my surprise, I discovered many of the products that I found in the patents from 1854 through 1921 had been revived by

contemporary product developers. In fact, the only really novel changes in sanitary protection since 1921 appears to have been the invention of superabsorbents and the adhesive-backed pads.

The tampon as it evolved for menstrual use also needs to be explored. During my research, I did collect some tampon patents from 1854 to 1921. In a comparison with Gutcho's reproductions (1979), I also discovered that many of the late 1970s tampons are almost identical in configuration to the tampons from 1854 to 1921.

Why sanitary protection product design has apparently stagnated is an interesting question. Most curious, however, is why, with so many people who have worked on and continue to work on developing menstrual products, a truly satisfactory one has not yet been developed.

REFERENCES

- Adamson, P. B. (1991). Surgery in ancient Mesopotamia. *Medical History*, 35, 428-435.
- Arpad, S. (Ed.). (1984). *Sam Curd's diary: The diary of a true woman*. Athens, OH: Ohio University Press.
- Apple, R. D. (1984). Pictorial essay. In J. W. Leavitt (Ed.) *Women and health in America: Historical readings* (pp. 286-297). Madison, WI: The University of Wisconsin Press.
- Barlow, W. B., & Powell, D. O. (1984). Homeopathy and sexual equality: The controversy over coeducation at Cincinnati's Pulte Medical College, 1873-1879. In J. W. Leavitt (Ed.) *Women and health in America: Historical readings* (pp. 422-428). Madison, WI: The University of Wisconsin Press. (Original work published 1981)
- Blackwell, E. (1858). *The laws of life, with special reference to the physical education of girls*. New York: A. O. Moore.
- Blocker, J. S., Jr. (1989). *American temperance movements: Cycles of reform*. Boston: Twayne Publishers.
- Bordin, R. (1990). *Woman and temperance: The quest for power and liberty, 1873-1900*. New Brunswick, NJ: Rutgers University Press. (Original work published 1981)
- Bradshaw, M. (1988). *Regions and regionalism in the United States*. Jackson, MS: University Press of Mississippi.
- Brownmiller, S. (1984). *Femininity*. New York: Linden Press/Simon & Schuster.
- Buckley, T., & Gottlieb, A. (Eds.). (1988). *Blood magic: The anthropology of menstruation*. Berkeley & Los Angeles: University of California Press.
- Bullough, V. (1979). Female physiology, technology and women's liberation. In M. Trescott (Ed.) *Dynamos and virgins revisited: Women and technological change in history* (pp. 236-251). Metuchen, NJ: The Scarecrow Press.
- Bullough, V. (1985). Merchandising the sanitary napkin: Lillian Gilbreth's 1927 survey. *Signs: Journal of Women in Culture and Society*, 10(3), 615-627.

- Bullough, V., and Voght, M. (1973). Women, menstruation, and nineteenth century medicine. *Bulletin of the History of Medicine*, 47(1), 66-82.
- Busch, J. (1992). *Happily ever after? American women and the disposable sanitary napkin*. Manuscript submitted for publication.
- Bushman, R. L., & Bushman, C. L. (1988). The early history of cleanliness in America. *The Journal of American History*, 74(4), 1213-1238.
- Byrn, E. E. (1900). *The progress of invention in the nineteenth century*. New York: Munn & Co.
- Clarke, E. (1873). *Sex in education: or a fair chance for girls*. Boston: James R. Osgood & Co.
- Cohn, D. L. (1940). *The good old days: A history of American morals and manners as seen through the Sears, Roebuck catalogs*. New York: Simon & Schuster.
- Cole, G. S. (1900). *Coles' encyclopedia of dry goods* (rev. ed.). Chicago & New York: Root Newspaper Association.
- Cowan, R. S. (1979). From Virginia Dare to Virginia Slims: Women and technology in American life. In M. M. Trescott (Ed.) *Dynamos and virgins revisited: Woman and technological change in history* (pp. 30-44). Metuchen, NJ: The Scarecrow Press. (Original work published 1977)
- Cunnington, C. W., & Cunnington, P. (1981). *The history of underclothes*. London: Faber & Faber. (Original work published 1951)
- Delaney, J., Lupton, M. J., & Toth, E. (1988). *The curse: A cultural history of menstruation*. Chicago: University of Illinois Press. (Original work published 1976)
- Donegan, J. (1978). *Women and men midwives: Medicine and misogyny in early America*. Westport, CT: Greenwood Press.
- Donegan, J. B. (1986). *"Hydropathic highway to health": Women and water-cure in antebellum America*. New York: Greenwood Press.
- Drury, C. M. (Ed.). (1963a). *First white women over the Rockies: Diaries, letters, and biographical sketches of the six women of the Oregon Mission who made the overland*

- journey in 1836 and 1838 (Vol. 1: Mrs. Marcus Whitman, Mrs. Henry Spalding, Mrs. William H. Gray, and Mrs. Asa B. Smith). Glendale, CA: The Arthur H. Clark Company.
- Drury, C. M. (Ed.). (1963b). **First white women over the Rockies: Diaries, letters, and biographical sketches of the six women of the Oregon Mission who made the overland journey in 1836 and 1838** (Vol. 2: Mrs. Elkanah Walker and Mrs. Cushing Eells). Glendale, CA: The Arthur H. Clark Company.
- Drury, C. M. (Ed.). (1966). **First white women over the Rockies: Diaries, letters, and biographical sketches of the six women of the Oregon Mission who made the overland journey in 1836 and 1838** (Vol. 3: Diary of Sarah White Smith (Mrs. Asa B. Smith), Letters of Asa B. Smith and other documents relating to the 1838 Reenforcement to the Oregon Mission). Glendale, CA: The Arthur H. Clark Company.
- Eccles, A. (1982). **Obstetrics and gynaecology in Tudor and Stuart England**. London: Croom Helm.
- Ecob, H. G. (1892). **The well-dressed woman: A study in the practical application to dress of the laws of health, art, and morals**. New York: Fowler & Wells.
- Ehrenreich, B., & English, D. (1978). **For her own good: 150 years of the experts' advice to women**. Garden City, NJ: Anchor Press/Doubleday.
- Ewing, E. (1978). **Dress and undress: A history of women's underwear**. New York: Drama Book Specialists.
- Farrell-Beck, J. (1994). [Pharmaceutical supply houses and sanitary protection products]. Unpublished raw data.
- Farrell-Beck, J., & Kidd, L. K. (1993, June). **Women's sanitary products: A nineteenth-century innovation**. Paper presented at the 19th Annual Meeting and Symposium of the Costume Society of America, Seattle, WA and Victoria, BC.
- Faragher, J. M. (1991). **The Midwestern farming family, 1850**. In L. K. Kerber & J. S. DeHart (Eds.) **Women's America: Refocusing the past** (3rd ed.) (pp. 119-132). New York: Oxford University Press. (Originally published 1979)

- French, E. (1987). **Emily: The diary of a hard-worked woman** (J. Lecompte, Ed.). Lincoln, NE: The University of Nebraska Press.
- Gutcho, M. (1979). **Tampons and other catamenial receptors**. Park Ridge, NJ: Noyes Data Corporation.
- Harlow, S. D. (1986). **Function and dysfunction: A historical critique of the literature on menstruation and work**. In V. L. Olesen & N. F. Woods (Eds.), **Culture and menstruation** (pp. 39-50). Washington, DC: Hemisphere Publishing Corporation.
- Hollick, F. (1853). **The matron's manual of midwifery, and the diseases of women during pregnancy and in childbed**. New York: T. W. Strong.
- Howe, J. W. (Ed.). (1972). **Sex and education: A reply to Dr. E. H. Clarke's "Sex in education."** New York: Arno Press. (Original work published 1874)
- Israel, F.L. (Ed.). (1968). **1897 Sears, Roebuck catalogue**. New York: Chelsea House.
- Jalland, P. (1986). **Women from birth to death: The female life cycle in Britain, 1830-1914**. Brighton: The Harvester Press, Ltd.
- Kerber, L. K. (1991). **Essential documents**. In L. K. Kerber & J. S. DeHart (Eds.) **Women's America: Refocusing the past** (3rd ed.) (pp. 525-556). New York: Oxford University Press. (Originally published 1979)
- Kobrin, F. (1984). **The American midwife controversy: A crisis of professionalism**. In J. W. Leavitt (Ed.) **Women and health in America: Historical readings** (pp. 318-326). Madison, WI: The University of Wisconsin Press. (Original work published 1966)
- Law, H., & Law, H. E. (1908). **Viavi hygiene** (rev. ed.). London: Stationer's Hall. (Original work published 1899)
- Leavitt, J. W. & Walton, W. (1984). **"Down to death's door": Women's perceptions of childbirth in America**. In J. W. Leavitt (Ed.), **Women and health in America: Historical readings** (pp. 155-174). Madison, WI: The University of Wisconsin Press. (Original work published 1981)

- Lensink, J. N. (Ed.). (1989). **"A secret to be burried": The diary and life of Emily Hawley Gillespie, 1858-1888.** Iowa City, IA: University of Iowa Press.
- Litoff, J. B. (1978). **American midwives: 1860 to the present.** Westport, CT: Greenwood Press.
- Luchetti, C. (1982). **Women of the west.** St. George, UT: Antelope Island Press.
- Macdonald, A. L. (1992). **Feminine ingenuity: Women and invention in America.** New York: Ballantine Books.
- Midwife: or old woman's magazine.** (1750-1753). London: Printed for Mary Midnight.
- Modern hygiene.** (1930, October 13). *Vogue*, pp. 81, 120, 122, 124, 126.
- Morantz, R. M. (1977). **Nineteenth century health reform and women: A program of self-help.** In G. B. Risee, R. L. Numbers, & J. W. Leavitt (Eds.), **Medicine without doctors: Home health care in American history** (pp. 73-93). New York: Science History Publications.
- Mosher, C. D. (1927). **Personal hygiene for women.** Stanford, CA: Stanford University Press.
- Myres, S. L. (Ed.). (1980). **Ho for California!** San Marino, CA: Henry E. Huntington Library and Art Gallery.
- Napheys, G. H. (1870). **The physical life of woman: Advice to the maiden, wife, and mother** (6th ed.). Philadelphia: Geo Maclean.
- The 1902 edition of the Sears, Roebuck catalogue.** (1969). New York: Bounty Books.
- Palmer, R. L., & Greenberg, S. K. (1936). **Facts and frauds in woman's hygiene.** New York: Vanguard Press.
- Patten, M. C. (1909-1910). **The hygiene of menstruation.** *American Journal of Nursing*, 10, 382-387.
- Payne, B., Winakor, G., & Farrell-Beck, J. (1992). **The history of costume: From ancient Mesopotamia through the twentieth century** (2nd ed.). New York: HarperCollins.
- Petroski, H. (1992). **The evolution of useful things.** New York: Alfred Knopf.

- Powers, M. R. (1985). **A woman's overland journey to California** (W. B. Thorsen, Ed.). Fairfield, VA: Ye Galleon Press.
- Putnam-Jacobi, M. (1978). **The question of rest for women during menstruation**. Farmingdale, NY: Dabor Social Science Publications. (Original work published 1877)
- Rothman, S. M. (1978). **Woman's proper place: A history of changing ideals and practices, 1870 to the present**. New York: Basic Books.
- Rowland, B. (1981). **Medieval woman's guide to health: The first English gynecological handbook**. Kent, OH: The Kent State University Press.
- Saint-Laurent, C. (1966). **A history of ladies' underwear**. London: Michael Joseph.
- Schlissel, L. (1982). **Women's diaries of the westward journey**. New York: Schocken Books.
- Scholten, C. (1984). "On the importance of the Obstetrick Art": Changing customs of childbirth in America, 1760-1825. In J. W. Leavitt (Ed.), **Women and health in America: Historical readings** (pp. 142-154). Madison, WI: The University of Wisconsin Press. (Original work published 1977)
- Schroeder, F. (1976). **Feminine hygiene, fashion and the emancipation of American women**. *American Studies*, 17, 101-110.
- Schwartz, G. (Ed.). (1984). **A woman doctor's Civil War: Esther Hill Hawks' diary**. Columbia, SC: University of South Carolina Press.
- Shew, J. (1851). **The water cure manual** (Vol. 4). New York: Fowler & Wells.
- Shew, J. (1852). **Midwifery and the diseases of women**. New York: Fowler & Wells.
- Shorter, E. (1982). **A history of women's bodies**. New York: Basic Books.
- Showalter, E., & Showalter, E. (1972). **Victorian women and menstruation**. In M. Vincinus (Ed.), **Suffer and be still: Women in the Victorian age** (pp. 38-44). Bloomington, IN: Indiana University Press.

- Shuttle, P., & Redgrove, P. (1978). **The wise wound: Eve's curse and everywoman.** New York: Richard Marek Publishers.
- Smith-Rosenberg, C. (1974). Puberty to menopause: The cycle of femininity in nineteenth-century America. In M. S. Hartman & L. Banner (Eds.), **Clio's consciousness raised: New perspectives on the history of women** (pp. 23-27). New York: Harpers Colophon Books.
- Smith-Rosenberg, C. (1991). The female world of love and ritual: Relations between women in nineteenth-century America. In L. K. Kerber & J. S. DeHart (Eds.) **Women's America: Refocusing the past** (3rd ed.) (pp. 179-197). New York: Oxford University Press. (Originally published 1975)
- Souder, M. (1917). **Department store merchandise manuals: The notion department.** New York: Ronald Press.
- Stage, S. (1979). **Female complaints: Lydia Pinkham and the business of women's medicine.** New York: W. W. Norton & Company.
- Stanley, A. (1993). **Mothers and daughters of invention: Notes for a revised history of technology.** Metuchen, NJ: The Scarecrow Press.
- Starr, P. (1982). **The social transformation of American medicine: The rise of a sovereign profession and the making of a vast industry.** New York: Basic Books.
- Temkin, O. (1956). **Soranus' gynecology.** Baltimore, MD: The Johns Hopkins Press.
- Towle, J., & Bramall, J. (1986). **Midwives in history and society.** London: Croom Helm.
- Ulrich, L. T. (1990). **A midwife's tale: The life of Martha Ballard, based on her diary, 1785-1812.** New York: Alfred A. Knopf.
- Van Horn, S. H. (1988). **Women, work, and fertility, 1900-1986.** New York: New York University Press.
- Verbrugge, M. (1979). The social meaning of personal health: The Ladies' Physiological Institute of Boston and vicinity in the 1850s. In S. Reverby & D. Rosner (Eds.), **Health care in America: Essays in social history** (pp. 45-66). Philadelphia: Temple University Press.

- Vertinsky, P. (1990). **The eternally wounded woman: Women, doctors, and exercise in the late nineteenth century.** Manchester & New York: Manchester University Press.
- Warner, D. J. (1979). Women inventors at the Centennial. In M. M. Trescott (Ed.) **Dynamos and virgins revisited: Woman and technological change in history** (pp. 102-119). Metuchen, NJ: The Scarecrow Press.
- Weideger, P. (1975). **Menstruation and menopause: The physiology and psychology, the myth and the reality.** New York: Alfred A. Knopf.
- Willard, F. E. (1883). **Woman and temperance: or the work and workers of the Woman's Christian Temperance Union.** Hartford, CT: Parle Publishing.
- Williams, N. (1890). **The philosophy of clothing.** London: Thomas Laurie.
- Wood, A. D. (1984). "The fashionable diseases": Women's complaints and their treatment in nineteenth-century America. In J. W. Leavitt (Ed.), **Women and health in America: Historical readings** (pp. 222-238). Madison, WI: The University of Wisconsin Press. (Original work published 1973)
- Wood-Allen, M. (1905). **What a young woman ought to know** (rev. ed.). Philadelphia: The Vir Publishing Company.
- Yarwood, D. (1986). **The encyclopedia of world costume.** New York: Bonanza Books.

APPENDIX A

LIST OF WOMEN'S DIARIES

The diaries studied for this investigation were written by the following women:

Narcissa Prentiss Whitman, her letters written in diary form, during her life traveling to and establishing the Oregon missions, 1836-1847 (Drury, 1963a);

Eliza Hart Spalding, her diary written while traveling to and living in Oregon, as part of the Oregon missions, 1836-1838 (Drury, 1963a);

Mary Augusta Dix Gray, her diary written while traveling to and serving in the Oregon missions, 1840-1842 (Drury, 1963a);

Mary Richardson Walker, her diary recording her Oregon mission experience, 1838-1848 (Drury, 1963b);

Myra Fairbanks Eells, her travel diary en route to the Oregon missions, 1838 (Drury, 1963b);

Sarah White Smith, her letters written while traveling to and living at the Oregon missions, 1838-1839 (Drury, 1966);

Jane McDougal and her diary written in May 1849 during her voyage from San Francisco to Indianapolis, via steamer and over the Ithmus of Panama (Myres, 1980);

Mary Stuart Bailey, diary written April to October 1852 during her overland journey from Ohio to California (Myres, 1980);

Helen Carpenter, diary written May to October 1857 during her overland journey from Kansas to California (Myres, 1980);

Mary Rockwood Powers, diary written 1856 to 1858, during her overland journey from Illinois to California (Powers, 1985);

Emily Hawley Gillespie, diary written 1858-1888 (Lenskink, 1989);

Mary Samuella Hart Curd, diary written 1860 to 1863, during her marriage when living in Missouri (Arpad, 1984);

APPENDIX A

LIST OF WOMEN'S DIARIES

The diaries studied for this investigation were written by the following women:

Narcissa Prentiss Whitman, her letters written in diary form, during her life traveling to and establishing the Oregon missions, 1836-1847 (Drury, 1963a);

Eliza Hart Spalding, her diary written while traveling to and living in Oregon, as part of the Oregon missions, 1836-1838 (Drury, 1963a);

Mary Augusta Dix Gray, her diary written while traveling to and serving in the Oregon missions, 1840-1842 (Drury, 1963a);

Mary Richardson Walker, her diary recording her Oregon mission experience, 1838-1848 (Drury, 1963b);

Myra Fairbanks Eells, her travel diary en route to the Oregon missions, 1838 (Drury, 1963b);

Sarah White Smith, her letters written while traveling to and living at the Oregon missions, 1838-1839 (Drury, 1966);

Jane McDougal and her diary written in May 1849 during her voyage from San Francisco to Indianapolis, via steamer and over the Ithmus of Panama (Myres, 1980);

Mary Stuart Bailey, diary written April to October 1852 during her overland journey from Ohio to California (Myres, 1980);

Helen Carpenter, diary written May to October 1857 during her overland journey from Kansas to California (Myres, 1980);

Mary Rockwood Powers, diary written 1856 to 1858, during her overland journey from Illinois to California (Powers, 1985);

Emily Hawley Gillespie, diary written 1858-1888 (Lenskink, 1989);

Mary Samuella Hart Curd, diary written 1860 to 1863, during her marriage when living in Missouri (Arpad, 1984);

Dr. Esther Hill Hawk, diary written 1862 to 1865 during her husband's tenure working for the National Freedman's Relief Association in South Carolina and Florida (Schwartz, 1984);

Harriet Bunyard, diary written 1869-1870, during her overland journey from Texas to California (Myres, 1980);

Maria Shrode, diary written in 1870, during her overland journey from Texas to California (Myres, 1980);

Emily French, who also worked as a nurse, diary written after her divorce in Colorado, 1890 (French, 1987);

Lillian Schlissel's (1982) research into women's diaries and the diaries contained in that work: the diaries of Catherine Haun (1849), Lydia Allen Rudd (1852), Amelia Stewart Knight (1853), and Jane Gould Tourtillott (1862).

APPENDIX B

MENSTRUAL PRODUCT PATENT LIST, 1854-1921

(The names and cities are spelled as they appear on the patents.)

Catamenial Supporter or Catamenial Ameliator

Alfred A. Starr 11,574
 New York, New York August 8, 1854
 Belt only: consisting of four light elastic steel springs to which napkins may be attached.

Catamenial Sack or Catamenial Bandage

N. Jensen 22,293
 Washington, D.C. December 14, 1858
 Waistband with three elastic straps attached to steelwire spring to which bag of impervious material (oil silk, india rubber) is attached which contains raw cotton or sponge.

Catamenial Sack, Catamenial Bandage, Improved Menstrual Receiver or Truss

Charles E. Clark, assignor to himself and Geo. W. Clark 23,059
 Boston, Massachusetts February 22, 1859
 Catamenial sack only: vulcanized caoutchouc, inflated with air to cushion wearer; intended to hold soft sponge.

Catamenial Bandage or Menstrual Instrument

Florian Dahis
 Frederick Doermer 29,362
 Brooklyn, New York July 31, 1860
 Padded spring to fit around hips; open at back; cup of india rubber attached to hip belt in the front; reusable sponge placed in cup.

Improved Female Supporter or Truss or Catamenial Sack

Alexander Damiens Reeves 34,845
 Portland, Maine April 1, 1862
 For both male and female use; also can be used for "periodical receptacle"; waist strap to which is attached an india rubber sack that contains a sponge.

Catamenial Sack or Catamenial and Urinal Bandages and Receptacles

Madison Vedder 35,338
 New York, New York May 20, 1862
 Soft vulcanized india rubber bags, one for vagina, one as urine catcher; have pipes so can discharge liquid discreetly; attached by straps to waistband; can be used when traveling for convenience.

Catamenial or Periodical Bandage

David F. Robertson 45,523
 Middletown, New York December 20, 1864
 Elastic belt (that goes on over feet) to wear above pelvis; elastic straps attach belt to impervious sack that contains a sponge or an absorbent.

Catamenial Sack

Edward L. Perry 49,915
 New York, New York September 12, 1865
 Sack of gutta percha or india rubber folded to form wings; place moistened sponge or cotton batting in pouch.

Catamenial Sack

Joseph C. Benzinger, M.D. 57,665
 Catonsville, Maryland September 4, 1866
 Waist girdle of "fine leather" and sack of fine and soft morocco; trough in sack that holds absorbent.

Catamenial Guard and Supporter

John A. Belvin, Jr. 68,688
 Baltimore, Maryland September 10, 1867
 "Womb supporter" sack into which sponge is placed; attached to waistbelt.

Catamenial Sack

S.L. Hockert, assigned to himself and Jared Thompson Sr. of Milwaukee, Wisconsin 70,843
 Chicago, Illinois November 12, 1867
 Menstrual receiver consisting of a cup-shaped ring (of rubber, gold, silver, or any suitable material) attached to a rubber sack or bag, with a sponge inside the bag for greater absorption. Receiver fits inside the vagina, and is attached to a waistbelt.

Catamenial Sack

Charles Manheim, assignor to E.L. Perry 75,036
 New York, New York March 3, 1868
 Sack only: rubber pouch with compartments for
 sponge or other absorbent.

Catamenial Sack and Belt

H.W. Libbey, M.D. 75,434
 Cleveland, Ohio March 10, 1868
 Sack of oiled silk or rubber with elastic at sides
 to give it form; attaches to belt; sponge.

Catamenial Sack

Andrew F. Baum, assigned to L.H. Rockwell 78,414
 New York, New York June 2, 1868
 Sack only: india rubber in elliptical shape with
 rolled edges.

Supporter for Stockings

Elizabeth Daniels 81,479
 Boston, Massachusetts August 25, 1868
 Stocking and "diaper" supporter for women. Elastic
 waistbelt to which are attached two sets of straps:
 one set for stockings (side of the belt) and one set
 as "diaper-supporter" (center front and center
 back). Elastic material and buckles; can also
 detach straps from waistbelt and re-attach to waist
 of drawers for children.

Catamenial Sack or Sac

George E. Brinckerhoff 84,083
 Brooklyn, New York November 17, 1868
 Sack of molded india rubber attached to elastic
 waistband; sponge as absorbent.

Menstrual Receiver or Catamenial Sack

Theodore A. Gamage 84,874
 Boston, Massachusetts December 15, 1868
 Belt to which is attached a bag or cup of oiled silk
 supported by metal plate to hold absorbing pad in
 place (sponge or other absorbent material).

Lady's Safety Belt

Mary G. Porter 99,347
 Charlestown, Massachusetts February 1, 1870
 Waistbelt to which is attached (via elastic straps)
 front and back flaps to which the "ordinary cloth or
 bandage" is pinned.

Catamenial Sack

Warren A. Dinsmore,
 assigned to himself and Emily L. Geer 105,785
 South Boston, Massachusetts July 26, 1870
 Sack-within-a-sack that traps discharge; tapering
 sack is attached to waistband; sponge "saturated
 with perfume" may be attached to upper sack edges.

G.C. Stillson's Ladies Elastic Supporter

G.C. Stillson 116, 882
 Derby, Connecticut July 11, 1871
 Triangular supporter, front and back yokes, partly
 elastic, buckle at side; two elastic fabric covered
 rings (shirred) at tip of yokes to which cloth is
 fastened and secured with a variation of a safety
 pin.

Ladies' Paper Towels

Joseph H. Hatch, one half assigned to Joseph W.
 Spaulding of Richmond, Maine 162,647
 Melrose, Massachusetts April 27, 1875
 Paper pads, layered, with one layer waterproof; also
 elastic belt and strap.

Catamenial Sacks

George Meacom 168,515
 Beverly, Massachusetts October 5, 1875
 Sack only: To improve upon Dinsmore's patent; inner
 and outer sack; waistband; sacks also securely
 attached to thighs with straps.

Suspenders

Stephen K. Ellis 169,245
 Waltham, Massachusetts October 26, 1875
 Suspenders to support "diaper" for women; has
 buckles and wire loops; supports the menstrual cloth
 from the shoulders.

Catamenial Sack or Menstrual Protectors

Frank A. Knabe 174,540
 Cincinnati, Ohio March 7, 1876
 Muslin or linen belt; morocco bandage attached to
 belt; folding receptacle/pocket for napkins.

Catamenial Sacks

George E. Johnston 182,024
 Chicago, Illinois September 12, 1876
 Sack of impervious material (shaped like a coin
 purse) to pass around "limbs" of "patient" for

security; india rubber receiving cup inserted in vagina.

Catamenial Sack or Menstruation-Confiner

Gustav Schilling, assignor of one-half to Carl
Gottfried von Platen 205,912
Chicago, Illinois July 9, 1878
Waist girdle attached to elliptical funnel shaped
rubber cap to cover vulva, connected to a rubber bag
receptacle, open at end to that bag may be emptied.

Catamenial Sack or Menstrual Pads

John Korff 235,884
Boston, Massachusetts December 28, 1880
Napkin only: hollow flexible core of soft paper
surrounded by absorbent cotton; wire loop through
core, ends secured to suspenders on a waistbelt.

Catamenial Sack and Abdominal Supporter; Catamenial Bandages

Ignatius Wasserman 267,956
New York, New York November 21, 1882
Knitted supporter of elastic netting to support the
absorbent pad of wool or cotton with a waterproof
backing; pad is detachable; elastic thigh straps and
waistband.

Fibrous Absorptive Pad

Darius Goff 271,625
Pawtucket, Rhode Island February 6, 1883
Absorbent pad of a sliver of chemically-treated
absorbent fiber enclosed within a braided seamless
fabric; strings at each end for attachment purposes.

Monthly-Protector

Gertrude Campbell 276,770
Chicago, Illinois May 1, 1883
Waistband, attached to supporter, in the center of
which is placed "ordinary napkins."

Catamenial Sack

Louise Lange 282,201
New York, New York July 31, 1883
Elastic waistbelt with suspension pieces to which
absorbent pad or bandage is attached; bandage is
pouch filled with small pieces of sponge with
antiseptic solution; tapers to the front and is
wider in the rear.

- Catamenial Sack or Supporting Belt for Absorptive Pads**
 Nannette Amia 296,104
 Brooklyn, New York April 1, 1884
 Supporting belt for use with fibrous absorptive pad
 Patent No. #272,625, Darius Goff, February 6, 1883.
- Catamenial Sack**
 Charles H. Levy 297,274
 New York, New York April 22, 1884
 Leather or rubber with longitudinal opening with
 frame to which a leather or rubber funnel or pocket
 shaped piece hangs from frame into which a sponge or
 cotton is placed.
- Menstrual Receptacle**
 Hiram G. Farr 300,770
 Boston, Massachusetts June 24, 1884
 Vaginal cup, into which discharge flows through a
 tube to an elastic receptacle; can be emptied by
 unscrewing a screw; can connect to waistband.
- Catamenial Sack or Bands for Supporting the Absorptive Cloth
 or Pad**
 Aurie Valon Robinson 366,256
 Fort Ann, New York July 12, 1887
 Band only: curved, laced at sides with rubber
 laces; napkins fastened through front and back
 loops.
- Catamenial Sack or Improved Lady's Towel**
 John Hothersall 384,525
 Manchester, England June 12, 1888
 Pad only: longitudinal strip with section of soft
 cloth attached and folded for four thicknesses; can
 be thick and thin as needed.
- Catamenial Sack**
 William S. Watson, assignor of one-half to Henry
 B. Bevier 393,408
 Matteawan, New York November 27, 1888
 Waistbelt, to which is attached a receptacle of
 rubber with a spring wire for holding mouth open;
 raw cotton, sponge or other absorbent material
 placed inside; may be medicated; may also be used
 for after childbirth or for containment of urine.

Catamenial Sack

Pamelia M. Boleman 393,882
 New York, New York December 4, 1888
 Waistband, attached to sack or shield, and removable
 pad; "limb" straps to secure sack.

Catamenial Sack

Emma Aubrey Wiley 395,411
 Los Angeles, California January 1, 1889
 Elastic rubber sack completely encasing lower body;
 at bottom of sack have hanging pocket containing
 sponge, soft linen, or other absorbent; drawstring
 or tape at waist.

Catamenial Sack or Catamenial Bandages

William R. Steinmetz
 Cornelia Steinmetz 415,475
 Baltimore, Maryland November 19, 1889
 Body belt (and thigh straps) with straps connecting
 cover or sheet rubber, oil cloth; absorbent pad of
 an outer case of cheesecloth and a highly-absorbent
 stuffing of layers of raw cotton and wood fiber
 treated with antiseptic solution; can also be used
 for after childbirth or for other discharges.

Catamenial Bandage

Julius Teufel 420,978
 Stuttgart, Germany February 11, 1890
 Waistband; detachable sack of rubber cloth in the
 shape of a trough into which is placed an absorbent
 pad filled with wood-wool wadding or other
 absorbent; may be medicated.

Napkin Belt

Ellen M. Preston, assignor of
 one half to Herbert I. Gould 423,572
 Providence, Rhode Island March 18, 1890
 Belt of textile material and elastic inserts.
 Weight is primarily on hips to avoid back and
 abdomen strain; metal buckles or buttons as
 closures.

Catamenial Sack or Safety-Belt for Catamenial Sack

Georgianna Fuller 438,537
 Gloversville, New York October 14, 1890
 Belt, with shield and frame attached; napkin is
 secured in shield by using frame.

Catamenial Sack or Suspensory Bandages or Belt

Annie Jenness Miller 458,035
 Dansville, New York August 18, 1891
 Waistband, material cut on bias; bag or pocket into
 which a napkin is place; also an abdominal
 supporter.

Catamenial Sack and Supporter

Annie Willoughby 463,819
 Philadelphia, Pennsylvania November 24, 1891
 Suspenders to which a pouch of soft rubber large
 enough to hold a sponge is attached; also can be
 used as a garment supporter.

Catamenial Sack or Menstrual Receptacle

Julius J. Vernier 467,963
 Toledo, Ohio February 2, 1892
 Vaginal cup; discharge flows through telescoping
 tube into waterproof receptacle.

**Catamenial Sack or Bandage or Catamenial or Surgical
Bandages**

Emma Howard Carpenter 470,983
 Springfield, Vermont March 15, 1892
 Rectangular bandage formed by folding a cloth with
 flocculent material (white cotton waste) in center;
 fastened to waistband; can also be used after
 childbirth.

Catamenial Sack

Hannah F. Ferguson 474,378
 Fort Erie, Canada May 10, 1892
 Waistband to which is attached a sack of soft
 rubber. Also Canadian patent #33,968, March 20,
 1890.

Catamenial Bandage

Anna Chapman 475,199
 Jersey City, New Jersey May 17, 1892
 Waistband to which removable bandage of vulcanized
 rubber material is attached; may connect an
 absorbent pad to bandage with safety pins.

Catamenial Sack or Ladies' Belt

Henry Smith 475,820
 London, England May 31, 1892
 Belt of chamois to which a "towel" may be attached.

Catamenial Sack or Napkin Belt or Retainer and Shield

Roza I. Odell
 Clara S. Howell 476,676
 Baltimore, Maryland June 7, 1892
 Belt, to which is attached a napkin-shield of oiled
 silk or thin india-rubber in same shape as the
 napkin; napkin and shield are independently
 attached.

Catamenial Sacks

Nelson M. Dyer,
 assigned to Alphonse Bourlier and
 Emile Bourlier 478,053
 Louisville, Kentucky June 28, 1892
 Sack only: sack of impervious material with
 protecting wings; connects to waistband; wider at
 front than rear.

Catamenial Appliance

William H. Masser 480,876
 Los Angeles, California August 16, 1892
 Belt with semi-circular wire frame into which an
 absorbent pad is clamped; pad to be discarded.

Catamenial Sack

George Woodson Gaines 501,563
 Rockwood, Tennessee July 18, 1893
 Waistband connected to outer bandage of sheet rubber
 and inner bandage of carbolated or otherwise
 sterilized cotton; secured by safety pins.

Catamenial Sack

Eliza Kirwin 514,717
 Indianapolis, Indiana February 13, 1894
 Suspenders to which an india rubber shield is
 attached, into which a sponge shaped like a cup is
 placed.

Catamenial Sack or Ladies' Monthly Napkin

Edward Cowley Hornor 520,113
 Somerville, Tennessee May 22, 1894
 Waistband to which a napkin (a folded rectangle) is
 attached.

Suspensory Belt

Emma J. Pike 529,750
 London, England November 27, 1894
 Waistbelt of elastic material with front and back
 pendant of india rubber with three holes punched in;

thread end of napkin or cloth through any hole.
Also patented in Great Britain, No. 2,867, February
17, 1891.

Catamenial Sack

Philip W. Dautrich 535,980
Conway Springs, Kansas March 19, 1895
Vaginal ring and tube to also support womb and
prevent back pain during menstruation; tube clamped
to strap and attached to waistband.

Catamenial Sack or Catamenial Appliance

Mary E. Ballard 570,216
Indianapolis, Indiana October 27, 1896
Belt, napkins of several thicknesses may be
attached; can be put on and off without removing
corset; especially good for use when walking or
bicycling.

Catamenial Sack or Sanitary Support

Jennie L. Bornstein 574,378
Dayton, Ohio January 5, 1897
Sack only: rubber or rubber cloth, folded and sewn
to allow for "cloth or other device" to be easily
put in or out.

Catamenial Sack

Elizabeth Parker 595,861
Philadelphia, Pennsylvania December 21, 1897
Sack of oiled silk or muslin with elastic loops to
hold napkin in place; attached to waistbelt.

Catamenial Sack and Womb Supporter

Seth Beach 599,955
Toledo, Ohio March 1, 1898
Vaginal ring, with a neck that drains discharge into
a pendant sack.

Catamenial Garment and Pad Attachments

George R. Everson 623,658
Cincinnati, Ohio April 25, 1899
Pant-like garment, "half drawers", knitted; place a
pad into crotch that has waterproof shield; can use
sponge or ordinary pads.

Catamenial Sack

Albert L. Gray 626,159
 St. Louis, Missouri May 30, 1899
 India rubber sack, wider in front than back, into which is placed a "pledget" (sponge or absorbent cotton); small pocket in front for disinfectant or carbolic acid; can attach to waistband.

Menstrual Receptacle

Byron B. Shea 642,265
 Kansas City, Missouri January 30, 1900
 Receiver that is a tube placed in the vagina and uses air suction to receive discharge into the receiver-chamber; release valve at end.

Catamenial Appliance

Charles A. Moberg
 James E. Brady 660,388
 Portland, Maine October 23, 1900
 Frame and fabric at vaginal area; menstrual receiver in fabric into which the discharge flows and is transported via a tube to receptacle that is attached to the knee; may be attached to belt or corset.

Catamenial Sack

Daisey Paul Sonnehill 676,636
 New York, New York June 18, 1901
 Supporter/body of linen or cotton folded around absorbent material or napkin; can be attached to belt.

Menstrual Receptacle and Uterine Supporter

Jacob R. Lang 679,478
 Rockport, Indiana July 30, 1901
 Hard rubber instrument inserted in vagina with screw cap at lower end; combines functions of pessary, uterine supporter, and menstrual receptacle.

Catamenial Sack

Adelaide Cortland 686,028
 Pittsburg, Pennsylvania November 5, 1901
 Front and rear fastening on catamenial sack attaches to corset; sack.

Catamenial Bandage

Heinrich Bauer 696,538
 New York, New York April 1, 1902
 Body of rubber sheeting with flaps at the sides into
 which is an absorbent lining of flat pieces of
 sponge; can attach to belt or corset.

Suspending Device for Catamenial Bandages

Edna L. Scott 706,457
 Portland, Maine August 5, 1902
 Waistband with front and back loops of elastic to
 grip the end of bandage.

Catamenial Sack

Mattie M. Spaulding 708,933
 Chattanooga, Tennessee September 9, 1902
 Sack of flannel that rests on the hips of the
 wearer.

Catamenial Bandage

John F. James
 Robert M. Kippen 709,223
 Melbourne, Canada September 16, 1902
 Sack with rubber ovals inside to hold the
 labia/vagina shut so that nothing is discharged; can
 place absorbent in cavity; attaches to belt; useful
 for walking or traveling; permits women to wear
 "delicate, flimsy" clothes.

Catamenial Appliance

Theresa Minard 715,112
 Scio, Ohio December 2, 1902
 Belt to which is attached a cloth or protector.

Catamenial Napkin

Thomas C. Asplund 728,432
 New York, New York May 19, 1903
 Napkin only: cloth folded into suitable napkin; may
 insert non-absorbent material between pad and outer
 layer.

Sanitary Napkin Holders or Clasps

Frederick M. Baldwin 733,120
 Winterpark, Florida July 7, 1903
 Spring-clamp for holding napkins in position.

Catamenial Sack or Uterine Appliance

Lee H. Mallalieu
 Mildred Coke 737,258
 St. Louis, Missouri August 25, 1903
 Ring inserted in vagina connected to a flexible sack
 of waterproof material.

Catamenial Appliance

Hubert A. Ische
 August Leonard Ische 743,877
 Milwaukee, Wisconsin November 10, 1903
 Waistband to which is attached a rubber receiver
 with wings and straps to hold absorbent material;
 thigh bands.

Attaching Device for Sanitary Napkins

Charles A. Schopbach 749,453
 Aurora, Illinois January 12, 1904
 Triangular piece with stud and socket and safety pin
 clasp to attach to corset or from a body garment.

Catamenial Sack

Thomas Isley Griffith 765,074
 Pittsburg, Pennsylvania July 12, 1904
 Waistband, attached to support or sack that can hold
 absorbent material like medicated cotton; fits
 underneath the corset.

Catamenial Pad

John L. Minges 768,861
 Rochester, New York August 30, 1904
 Pad of triangular open-mesh material with pocket
 secured with tapes around waist and hips.

Clip for Catamenial Belt

Arthur E. Luzzi 774,191
 New York, New York November 8, 1904
 Waistbelt and clips to hold napkin front and rear;
 also provides belt with pair of hose supporters to
 increase usefulness of belt.

Catamenial Appliance

Helen Evans Scott 778,077
 Baltimore, Maryland December 20, 1904
 Apron suspended from waistband.

Catamenial Sack

Mary E. Coleman
 Meyer Jarmulowsky (a subject of Russia) 780,598
 New York, New York January 24, 1905
 Belt to which sack of stockinet with depression to
 hold absorbent pad is attached; has wings; medicated
 material suggested or sponge, cotton, or cloth.

Catamenial Bandages

Emma C. Morison 786,136
 New York, New York March 28, 1905
 Bandage or pad-holder suspended from waistband; pin
 napkin or pad to holder.

Catamenial Appliance

Mary Susan Merkley 791,354
 Brooklyn, New York May 30, 1905
 Waterproof bandage, tapered front and back, attached
 to waistbelt; pad is of "sponge rubber" (not natural
 rubber).

Sanitary Shield

Herbert E. Hudson, assignor by Mesne Assignments to
 the Sanitary Shield & Manufacturing Co. 794,181
 Cleveland, Ohio July 11, 1905
 Shield only: of gutta percha, celluloid and hard
 rubber; curved-in at sides to hold in "packing".

Sanitary Belt

Arthur M. Young 795,469
 Chicago, Illinois July 25, 1905
 Waistbelt with two elastic loops and napkin clasps
 to which napkin is securely held; appliance adapts
 to wearing or placement of corset.

Catamenial Sack

Joseph Griffith 807,923
 Springfield, Ohio December 19, 1905
 Sack or body that opens up to form receptacle into
 which "absorbent material, medicated material" is
 placed; also absorbs other uterine discharges;
 compact for storage and fits in a bureau drawer.

Absorptive Bandage

Willard R. Green, assignor to
 The American Absorbent Fiber Company
 of Portland, Maine 810,116 through 810,135
 Muscatine, Iowa January 16, 1906

Twenty patents for absorptive bandages or pads.
 Each has slight change or modification, but
 substantially is comprised of a cover-sheet, a
 filling, and an open-mesh surface fabric.
 Significant changes or modifications are as follows:
 #810,116--filling of excelsior; #810,117--"side-
 bracing member" to support bandage transversely and
 absorptive material of mingled wood strands;
 #810,119--"cellular intermediate member" (filling)
 placed to create a "corrugated body"; #810,121--sand
 or other "analogous granular material therein" used
 in combination with the absorbent material;
 #810,122--metallic cage to hold absorbent material
 so that side will not compress; #810,123--"chamber-
 space forming cage" in the absorbent material
 comprising a coil or helical-formed structure;
 #810,130--chamber-space forming member of coils of
 wire; #810,134--absorbent member of wood strands or
 vegetable fiber.

Catamenial Bandage

Edward Savage Dix, assignor to The Borated Specialty
 Company of Brooklyn 811,704
 New York, New York February 6, 1906
 Bandage/pad only: knitted fabric in tubular shape
 into which a pad of medicated cotton is placed;
 inside is a waterproof woven fabric reinforcement.

Self-Adjusting Belt for Supporting Catamenial Bandages

Eugenie Schick 813,176
 Fly Mountain, New York February 20, 1906
 Twilled linen or muslin waistbelt to which is
 attached the napkin.

Catamenial Sack

Wallace M. Longstreth 813,221
 Terra Alta, West Virginia February 20, 1906
 Open-work wire receptacle to hold absorbent (like
 antiseptic absorbent cotton).

Catamenial Sack

Carrie M. Greenwald 825,122
 New York, New York July 3, 1906
 Sack of "velvet rubber" with wings and straps to hold down pad of soft absorbent material that is tufted.

Catamenial Sack

David A. Powdermaker 826,881
 Philadelphia, Pennsylvania July 24, 1906
 Sack only: thin rubber sheet made into a channel or sack with straps that secure the napkin or other absorbent material; easily stored.

Belt Attachment for Sanitary Supports

Jennie L. Bornstein 828,809
 Dayton, Ohio August 14, 1906
 Provides a supporting belt for #574,378 (sack). Belt has a locking catch.

Catamenial Protector

Clara L. Williams 830,757
 Chicago, Illinois September 11, 1906
 Sack only: strip of "rubber cloth" with pocket at each end for securing napkin.

Catamenial Garment

Sarah G. Schiff 833,849
 New York, New York October 23, 1906
 Drawer-like garment with waterproof portions on buttock, crotch, and abdomen section; pin pad or napkin in.

Catamenial Sack

Jacob J. Shtuchka 844,198
 Rochester, New York February 12, 1907
 Sack of rubber cloth, goblet-shaped with stops to prevent backward flow; attaches to waistbelt.

Catamenial Bandage

Mary A. Cook 849,725
 Bridgeport, Connecticut April 9, 1907
 Waistband to which is attached shield or protecting strip of pure rubber with pocket to hold the bandage; bandage may be "folded cloth, absorbent cotton, paper or any material suitable".

Catamenial Sack

Frank X. Mathis, Jr.
 Lewis Simon 853,708
 Philadelphia, Pennsylvania May 14, 1907
 Sack of soft rubber with sides turned-in to form
 receptacle for "napkin, cloth, or other absorbent";
 attaches to belt.

Catamenial Appliance

William D. Berry 857,019
 Louisville, Kentucky June 18, 1907
 Hip-hugger belt with thigh bands to which pouch is
 attached into which absorbent material (cotton) is
 placed.

Sanitary Pad

William E. Wright 860,111
 Newark, New Jersey July 16, 1907
 Pad only: pad of corn pith with covering of
 cheesecloth; oval shape.

Catamenial Appliance

John F. Altermatt 867,091
 Missoula, Montana September 24, 1907
 Waistbelt to which is attached an "absorbent
 carrier" of non-absorbent material, wider at rear
 end and is trough-shaped, with stiffening wire at
 front of carrier to hold shape.

Catamenial Bandage

Wilhelmina Lauffs 879,778
 Zurich, Switzerland February 18, 1908
 Flat piece of cloth with pockets at sides left open
 into which is inserted wadding pads; sides folded
 in; india rubber layer at bottom.

Catamenial Bandage

Arthur R. Slater 880,928
 Fruitvale, California March 3, 1908
 Abdominal and rear bandage that fits around hips;
 attach catamenial pad to tabs front and back.

Catamenial Device

Abraham I. Jordan 881,130
 New York, New York March 10, 1908
 Oblong bag-shaped "member" of waterproof material
 with side wings; oblong absorbent pad of sponge or
 suitable material secured by netting.

Catamenial Bandage

Mary Emma Doyle 882,301
 Constableville, New York March 17, 1908
 Sanitary towels or surgical bandages of woven
 foundation piece folded to four thicknesses; back
 layer of non-absorbent cotton, all layers held in
 place by wrapping of knit or woven gauze; oil the
 netting with cottonseed oil to make netting non-
 absorbent yet allow liquid to pass through.

Sanitary Protector

Alice M. Aiken 899,196
 Cleveland, Ohio September 22, 1908
 An impermeable back shield suspended from waist to
 upper calf; safety pin section to sides of drawers.

Catamenial Appliance

Douglas S. Daudt 900,150
 Plainfield, New Jersey October 6, 1908
 Sack of rubber with frame to hold it in shape at the
 bottom of the sack; attached to waistband, has hip
 straps.

Catamenial Sack and Support

Harriet M. Richards,
 assignor to Woman's Mutual
 Benefit Company 901,742
 Joliet, Illinois October 20, 1908
 Supporter only: hip belt and straps to which
 napkins may be attached.

Sanitary Napkins

Otto C. Schulz, assignor to Bauer & Black 903,895
 Chicago, Illinois November 17, 1908
 Pad of absorbent cotton enclosed in holder of
 tubular casing of knitted gauze; ends are left for
 attachment; sews longitudinally to strengthen pad in
 longitudinal direction.

Catamenial Bandage

John A. Treber
 Bernhard Simon 909,349
 Deadwood, South Dakota January 12, 1909
 Body of article in panduriform shape (larger in and
 oil silk); depression in body to receive absorbent
 can attach to waistbelt.

Catamenial Receptacle

Paul J. Scheller
 Norman I. Haas,
 assignors of one-third to
 Elias Horn 913,983
 Evansville, Indiana March 2, 1909
 Narrow plate of metal or rubber, covering vulva to
 anus with elongated depression in center to which a
 funnel is attached into which discharges go; also
 can be used to catch urine.

Catamenial Sack

Franklin A. Frommann 924,337
 Dallas, Texas June 8, 1909
 Sack of para rubber, molded into a crescent shape;
 place absorbent (sponge) inside.

Catamenial Appliance

Douglas S. Daudt 924,644
 North Plainfield, New Jersey June 15, 1909
 Sack of soft rubber with removable spring inside to
 prevent collapse of sack.

Catamenial Bandage

Isabel La Bonta Plamondon 929,166
 Provemont, Michigan July 27, 1909
 Pad or sack with cords at edges to prevent
 displacement of pad; waistbelt and thighbands.

Catamenial Bandage

Clara B. Cahoon 938,967
 New York, New York November 2, 1909
 Folded sheets of absorbent crape paper and band of
 gauze fabric (cheesecloth) with extending ends for
 attachment.

Catamenial Garment

Anna L. Brodton, assignor of one-half to Emile Tacon
 and Eva G. Tacon 939,943
 Mobile, Alabama November 9, 1909
 Flat piece of thin rubber cloth folded into pant-
 like garment; napkin secured inside; no stitched
 seams, use "cement".

Catamenial Bandage

Manly M. Gillam 951,184
 New York, New York March 8, 1910
 Hip belt to which is attached bandage of muslin treated with rubber that has wings and flaps at either end to hold napkin or other absorbent.

Sanitary Napkin and Belt for Supporting Same

James H. Johnson 964,267
 Washington, D.C. July 12, 1910
 Waistbelt to which is attached a folded 5 layered bandage with inner sheet of rubber cloth or oiled silk.

Catamenial Garment

Sallie M. Taylor 972,288
 St. Louis, Missouri October 11, 1910
 Waistband with "catamenial section of waterproof material" attached with safety pin; can secure "towel" with safety pin to sack.

Combined Abdominal Supporter and Catamenial Sack

Rudolph Keagy
 Martin L. Keagy, assignors of one half to Daniel L. Holwick 976,883
 Canton, Ohio November 29, 1910
 Waistbelt, hip belt, and thigh belt with abdominal supporter or apron; sack is spheroid shaped single piece of rubber and has a wire gauze screen over opening to prevent from closing and collect clots; a back draining receptacle.

Catamenial Bandage

Ida M. Argo 979,730
 Dallas, Texas December 27, 1910
 Supporting member of two layers separated by padding of absorbent cotton with dart to give some shape; pad is similar to supporting member with layers of rubber with pads in between; pocket on pad in which filling of medicated cotton is placed; fits closely so that wrinkle won't show through outergarment.

Catamenial Bandage

Olga J. Miller-Jones 1,003,487
 West New Brighton, New York September 19, 1911
 Bandage only: square cloth folded on bias into rectangle under tension so becomes slightly ellipsoidal; can use any absorbent material and filling of absorbent material.

Catamenial Napkins

Elizabeth Sprague 1,022,894
 Minneapolis, Minnesota April 9, 1912
 Napkin of inner sheet of rubberized silk sandwiched
 between layers of sterilized cotton and quilted
 together with other covering of cheesecloth; forms
 wings when worn.

Catamenial Sack

Jennie L. Bornstein 1,041,420
 Dayton, Ohio October 15, 1912
 An improvement on her previous patented menstrual
 products; belt, supporter, and instructions for
 washable, reusable pads and disposable pads.

Catamenial Appliance

Otto Czarán (a subject of Hungary) 1,052,218
 New York, New York February 4, 1913
 Flexible wires bent in shape of a woman, covered
 with non-absorbent and moisture-proof material with
 slot for catamenial sack of rubber, tapers to front,
 may place absorbent material in sack.

Catamenial Sack

Mattie E. Siebert 1,053,069
 Spokane, Washington February 11, 1913
 Sack: a napkin support of muslin or impervious
 material, folded to be rectangular and fastened with
 safety pins to belt.

Catamenial Sack

William Goff Robey 1,054,619
 Grafton, West Virginia February 25, 1913
 Boat-shaped carrier with wings; pocket for absorbent
 material; waistbelt, thigh straps/belt.

Napkin or Skirt Protector

Margaret H. Hosack
 Ida R. Hosack 1,058,000
 Topeka, Kansas April 1, 1913
 Body or sheet of flexible rubber (may be medicated
 or sterilized) in diamond shape; secured at waist
 and at legs; to prevent staining.

Catamenial Device

Abraham I. Jordan 1,064,836
 New York, New York June 17, 1913
 Waistband attached to bag (the protector) which is oblong with lateral pockets (wings) into which absorption pad is placed.

Sanitary Protector

Grace Pfeil 1,067,841
 Chicago, Illinois July 22, 1913
 Drawers, belt, and an inner pocket which has opening for absorbent material; also garters for stockings; can also use a napkin; easy to use when "demands of nature" call.

Catamenial Sack

Ada L. Westfall 1,100,108
 Tampa, Florida June 16, 1914
 Hip belt with sack that is cloth ellipse with loops for holding pad or napkin; forms wings when wearing.

Sanitary Supports for Napkins

Delia Nesgood (a subject of Great Britain) 1,103,815
 West Brighton, New York July 14, 1914
 Support which is a sling of waterproof material with longitudinal side folds with elastic at ends to hold folds in place; insert napkin in sling; attached to belt.

Sanitary Napkin

George Rinke 1,107,447
 Detroit, Michigan August 18, 1914
 Napkin with crocheted or knitted tubular body portion with tabs at each end; use a stitch with longitudinal rib for better absorption; can also be used for infant diapers or where ever an absorbent pad is needed.

Catamenial Appliance

Leah G. Milkes 1,108,206
 Minneapolis, Minnesota August 25, 1914
 An apron of flexible waterproof material with straps so that napkin holder can be attached; place absorbent in holder; also has hose supporters.

Catamenial Appliance

John B. Des Rosiers 1,110,674
 Providence, Rhode Island September 15, 1914
 Body or shield of velvet rubber, wider in front; use
 safety pins to hold bandage in place; may attach to
 belt.

Catamenial Device

John Jorgenson 1,113,561
 San Francisco, California October 13, 1914
 Vaginal container/insert of non-corrosive metal to
 collect discharges and also offers uterine support.

Catamenial Appliance

Jennie C. Myers 1,122,988
 Palestine, Texas December 29, 1914
 Apron secured to rear of waistbelt; a shield portion
 attaches to front of waistbelt and makes a "saddle"
 for the napkin.

Sanitary Napkin

Masayoshi Kojima (a subject of Japan) 1,123,314
 Los Angeles, California January 5, 1915
 Absorption pad of shredded paper wrapped in
 absorbent paper, that rests on a non-absorbent paper
 shield; reinforcing fabric strip;

Napkin

Ernest A. De Rose (a subject of Italy) 1,131,483
 New York, New York March 9, 1915
 Shell-shaped sack with nipple and detachable cap as
 vent; has dependent wings or shield; may put
 absorbent into sack but don't need to; attaches to
 waistbelt.

Catamenial Appliance

Jacob Rubel, assignor to Standard Mail
 Order Company of New York 1,144,253
 New York, New York June 22, 1915
 Rear triangular shield with connecting device at
 back; comes up and attaches to small triangular
 yoke; can fasten a napkin to connecting devices.

Sanitary Napkin Holder

Sara Goldman 1,146,245
 San Francisco, California July 13, 1915
 Waterproof napkin holder and napkin of absorbent material (raw cotton); has side flaps that form pockets for securing napkin; rectangular shape narrowing at each end.

Catamenial Sack

Goodwin B. Smith 1,148,548
 Philadelphia, Pennsylvania August 3, 1915
 Cloth folded to form rectangle with a pocket into which insert absorbent material.

Sanitary Napkin

Natalie Marjorie Barlet, assigned to the
 Junoform Company 1,150,572
 Philadelphia, Pennsylvania August 17, 1915
 Bandage of plies with slots at each end through which supporting band is threaded; has waterproof backing.

Catamenial Sack

Louise M. Goodnou 1,157,774
 New York, New York October 26, 1915
 Waistbelt, thigh straps; sack has center support and side supports that form wings; use safety pins to attach sack to belt; place napkin or cloth inside of sack.

Napkin

Elfreda J. Corbin, assigned one-half
 to Jennie Bohmbach 1,158,182
 Minneapolis, Minnesota October 26, 1915
 Napkin of folded material; also has pocket if want to insert absorbent material for extra protection; napkin is sewn to waist-tie at back and is fastened by loops in the front (ties).

Catamenial Appliance

Frederic C. Cornell 1,159,362
 New York, New York November 9, 1915
 Holder forms wings; absorbent (that is covered with cheesecloth) safety pinned in; attaches to waistbelt.

Napkin-Holder

Charles Hayes Rutherford 1,168,679
 Jerome, Arizona January 18, 1916

Rubber holder with elastic strips to hold napkin in place; attached to belt.

Sanitary Pad or Bandage

Ida M. Joseph, assigned to Sol. H. Shoninger 1,169,490
 Chicago, Illinois January 25, 1916

Bandage of filling of strips or shreds of crape paper wrapped in another layer of paper forming bandage with ends; inner strip of reinforcing paper that is non-absorbent; bandage is safety pinned into a support, then attached to belt.

Catamenial Bandage

Albert T. Van Alstyn 1,175,090
 New York, New York March 14, 1916

Two pieces of fabric folded and stitched to form napkins which may be pinned to belt or support.

Catamenial Sack

Berthe Glaser 1,182,007
 Pittsburgh, Pennsylvania May 9, 1916

Napkin of bath toweling octogonol in shape, folded to form rectangle with a band of canton flannel in middle; has a loop on one end, and straps on other end; straps are ties around waist, through loop and then back again.

Catamenial Bandage

Lawrence W. Luellen, assigned to
 Individual Drinking Cup Company
 of New York, a Maine corporation 1,192,439
 Mountain Lakes, New Jersey July 25, 1916

Covering or envelop of soft absorbent cotton woven in tube form with filling of cotton, then formed by a machine in shape that allows it to be placed in individual packages for vending machines.

Catamenial Appliance

Sarah B. Potter 1,192,683
 Washington, D.C. July 25, 1916

Supporter/napkin that is square folded into a six-sided rectangular polygon; the sides fold over the absorbent material; attached to belt; no protuberances in clothing.

Catamenial Napkin

Elizabeth Sprague 1,195,621
 Minneapolis, Minnesota August 22, 1916

Napkin created by folding sheet of fabric into a rectangle that has a pocket for absorbent; also has a waterproof sheet in napkin; loops on napkin for attaching to waistbelt; can be sold from coin machines in sleeping cars, toilet and dressing rooms.

Catamenial Sack

Goodwin B. Smith, assigned to Junoform Company 1,222,899
 Philadelphia, Pennsylvania April 17, 1917

Tube or sleeve of gauze or netting, filled with absorbent soft material like cotton behind which a band is place to hold the tube in place.

Catamenial Appliance

Lester E. Norquist 1,241,652
 Denver, Colorado October 2, 1917

Vaginal insert: hard or soft rubber cup or vessel with ring at end; may place soft sponge or other absorbent material in vessel and insert in vagina; has flared rim; to eliminate the use of bandages.

Catamenial Appliance

Lester E. Norquist 1,263,797
 Denver, Colorado April 23, 1918

Vaginal insert: refer to #1,241,652; addition consists of sponge retaining spring and shape of vessel has changed slightly.

Catamenial Sack

Joseph Beck, assignor of one-half to
 Walter Edelstein of So. Boston 1,283,632
 New York, New York November 5, 1918

Sack with end extension; has a central opening or pocket into which a protector of thin rubber fits; an absorbent such as cotton or a pad is placed inside the pocket.

Catamenial Sack

Cora E. Dudley 1,288,848
 Philadelphia, Pennsylvania December 24, 1918
 Full garment (like panty) of scrim cloth with rubber
 seat portion; inside connections for carrier and pad
 attachment; to be worn as a "nether garment"; can
 also be used by elderly ladies past the "periodic
 age" and by stout people during hot weather.

Catamenial Appliance

Eva Steele 1,300,510
 Chicago, Illinois April 15, 1919
 Tape waistband with ties; also side hip belts; the
 shield protector forms wings and has a place for
 pad.

Reissue: Catamenial Bandage

Albert T. Van Alstyn Reissue 14,722
 Grand Rapids, Michigan September 9, 1919
 See #1,175,090, previous.

Catamenial Sack

Joseph J. Martinka 1,329,195
 Newark, New Jersey January 27, 1920
 A bifurcated gasket member formed of sponge section
 that rests on body made of celluloid; inside body
 can place absorbent.

Serviette or Catamenial Sack

Samuel Bottomley 1,332,597
 Providence, Rhode Island March 2, 1920
 Napkin only: tubular casing of woven mesh with
 absorbent pad placed inside; a drawstring runs along
 one longitudinal end of casing; once that is pulled,
 the casing is opened and the inside pad can be
 destroyed.

Reissue: Catamenial Bandage

Albert T. Van Alstyn Reissue 14,830
 Grand Rapids, Michigan March, 30, 1920
 See #1,175,090, previous.

Reissue: Catamenial Bandage

Albert T. Van Alstyn Reissue 14,924
 Grand Rapids, Michigan July 20, 1920
 See #1,175,090, previous.

Absorbent Pad

Joseph Cheney Baker 1,370,081
Syracuse, New York March 1, 1921
Shell or envelop of perforated paper in tubular form
filled with shredded absorbent material (like
shredded wood pulp).

Supporter of Catamenial Sacks or Napkins

Goodwin B. Smith 1,388,529
Philadelphia, Pennsylvania August 23, 1921
Elastic waistband only; can attach a napkin or sack
attached ribbon or tape or the "common safety pin".

APPENDIX C

ADJUSTMENTS TO PATENTEE NUMBERS

The real numbers of the men and women involved in patenting activity were determined by doing a "head-count" of the patentees. The first time that a repeat patentee was granted a patent was the only time the patentee as an individual was added into the real numbers of people involved in patenting menstrual products. Therefore, Jennie Bornstein, who patented in the nineteenth as well as the twentieth century, was only counted in the 1854-1899 numbers and NOT in the 1900-1921 numbers.

For the period 1854-1899, I counted 40 men, 23 women, and 4 "sex unknown" for a total of 67 people that were involved in patenting activity. For the period 1900-1921, I counted 61 men and 43 women for a total of 104 people that were involved in patenting activity.

The seven "repeat patentees" were as follows:

Jennie Bornstein, Dayton, Ohio, 3 patents: U.S.P. No. 574,378 (January 5, 1897), U.S.P. No. 828,809 (August 14, 1906), U.S.P. No. 1,041,420 (October 15, 1912);

Willard Green, Muscatine, Iowa, 20 patents: U.S.P. No. 810,116 through 810,135, inclusive, (January 16, 1906);

Douglas S. Daudt, Plainfield, New Jersey, 2 patents: U.S.P. No. 900,150 (October 6, 1908), U.S.P. No. 924,644 (June 15, 1909);

Abraham I. Jordan, New York, New York, 2 patents: U.S.P. No. 881,130 (March 10, 1908), U.S.P. No. 1,064,836 (June 17, 1913);

Elizabeth Sprague, Minneapolis, Minnesota, 2 patents: U.S.P. No. 1,022,894 (April 9, 1912), U.S.P. No. 1,195,621 (August 22, 1916);

Goodwin B. Smith, Philadelphia, Pennsylvania, 3 patents: U.S.P. No. 1,148,548 (August 3, 1915), U.S.P. No. 1,222,899 (April 17, 1917), U.S.P. No. 1,388,529 (August 23, 1921);

Lester Norquist, Denver, Colorado, 2 patents: U.S.P. No. 1,241,652 (October 2, 1917), U.S.P. No. 1,263,797 (April 23, 1918).

APPENDIX D

REGIONAL DIVISIONS BY STATE

The United States Bureau of Census divides the United States into the following regions:

- Northeast:** Maine, New Hampshire, Vermont, Massachusetts, Rhode Island, Connecticut, New York, Pennsylvania, and New Jersey.
- South:** Delaware, Maryland (including Washington, D.C.), Virginia, North Carolina, South Carolina, Georgia, Florida, Alabama, Tennessee, Kentucky, West Virginia, and Mississippi, Louisiana, Arkansas, Oklahoma, and Texas.
- Midwest:** Ohio, Michigan, Indiana, Illinois, Wisconsin, Iowa, Missouri, North Dakota, South Dakota, Nebraska, and Kansas.
- West:** Montana, Wyoming, Colorado, New Mexico, Idaho, Utah, Arizona, Nevada, Washington, Oregon, California, Alaska, and Hawai'i.

(Bradshaw, 1988, p. 4)

APPENDIX E

NAMES OF MENSTRUAL PRODUCTS FROM THE PATENTS

Menstrual products were referred to in patent titles by a variety of names. The names may be descriptive of the function or a part of the menstrual item. Frequently, however, the product was given a general, unspecific name.

Names for catamenial items included Catamenial Supporter, Catamenial Ameliator, Catamenial Bandage, Truss, Menstrual Instrument, Periodical Bandage, Catamenial Guard, Menstrual Receiver, Safety Belt, Menstrual Protectors, Menstruation-Confiner, Monthly Protector, Menstrual Receptacle, Napkin Supporter, Napkin Belt, Suspensory Bandages or Belt, Retainer and Shield, Catamenial Appliance, Ladies' Monthly Napkin, Sanitary Support, Sanitary Shield, Catamenial Protector, Catamenial Sack, Catamenial Device, Sanitary Protector, Catamenial Garment, Napkin or Skirt Protector, Sanitary Napkin, Sanitary Napkin Holder, Absorbent Pad, and Napkin.

APPENDIX F

DISPOSABLE MENSTRUAL PRODUCT PATENTS

The following is a list of patents for disposable sanitary pads or napkins:

Joseph H. Hatch, **Ladies' Paper Towels**, April 27, 1875, U.S.P. No. 162,647: paper pads;

John Korff, **Catamenial Sack or Menstrual Pads**, December 28, 1880, U.S.P. No. 235,884: soft paper core surrounded by absorbent cotton;

Darius Goff, **Fibrous Absorptive Pad**, February 6, 1883, U.S.P. No. 271,625: sliver of chemically absorbent fiber;

William R. Steinmetz and Cornelia Steinmetz, **Catamenial Sack or Catamenial Bandages**, November 19, 1889, U.S.P. No. 415,275: absorbent pad of an outer case of cheesecloth and absorbent stuffing of layers of raw cotton and wood fiber;

Julius Teufel, **Catamenial Bandage**, February 11, 1890, U.S.P. No. 420,978: absorbent pad filled with mediated wood wool wadding;

William H. Masser, **Catamenial Appliance**, August 16, 1892, U.S.P. No. 480,876: pad of netting, with layer of absorbent cotton and non-absorbent bottom layer;

George Woodson Gaines, **Catamenial Sack**, July 18, 1893, U.S.P. No. 501,563: carbolated cotton pad;

Willard Green, **Absorbent Bandage**, January 16, 1906, U.S.P. No. 810,116 through 810,135: excelsior filling (#810,116), wood strands (#810,117; #810,118), "mass of absorptive material" (#810,119), fine and coarse woody fibers (#810,120), absorbent and sand (#810,121), absorbent material (#810,122; #810,123; #810,125; #810,126; #810,127; #810,128; #810,130; #810,131; #810,132; #810,133; #810,135), "absorptive material, a body of sand or analogous granular material" (#810,124), absorbent fibrous material (#810,129), woody strands and "vegetable fiber" (#810,134);

Edward Savage Dix, assignor to The Borated Specialty Company, **Catamenial Bandage**, February 6, 1906, U.S.P. No. 811,704: tubular knit into which is placed a pad of medicated cotton with waterproof fabric reinforcement;

Carrie M. Greenwald, **Catamenial Sack**, July 3, 1906,
U.S.P. No. 825,122: soft, absorbent, tufted pad;

William E. Wright, **Sanitary Pad**, July 16, 1907, U.S.P.
No. 860,111: corn pith;

Otto C. Schulz, assignor to Bauer & Black, **Sanitary
Napkins**, November 17, 1908, U.S.P. No. 903,895: tubular knit
enclosing an absorbent cotton pad;

Clara B. Cahoon, **Catamenial Bandage**, November 2, 1909,
U.S.P. No. 938,967: crepe paper;

Masayoshi Kojima, **Sanitary Napkin**, January 5, 1915,
U.S.P. No. 1,123,314: shredded paper;

Sara Goldman, **Sanitary Napkin Holder**, July 13, 1915,
U.S.P. No. 1,146,245: cotton;

Ida M. Joseph, assignor to Sol. H. Shoninger, **Sanitary
Pad or Bandage**, January 25, 1916, U.S.P. No. 1,169,490:
shreds or strips of crepe paper wrapped in paper, with non-
absorbent Japanese paper inner strip;

Lawrence W. Luellen, assignor to Individual Drinking Cup
Company of New York, **Catamenial Bandage**, July 25, 1916, U.S.P.
No. 1,192,439: woven cotton tube with filling of cotton
(vending machine use);

Goodwin B. Smith, assignor to the Junoform Company,
Catamenial Sack, April 17, 1917, U.S.P. No. 1,222,899: tube
of gauze or netting, filled with absorbent soft material;

Samuel Bottomley, **Serviette or Catamenial Sack**, March 2,
1920, U.S.P. No. 1,332,597: tubular casing of woven mesh with
absorbent pad inside;

Joseph Cheney Baker, **Absorbent Pad**, March 2, 1920,
U.S.P. No. 1,370,081: perforated paper filled with shredded
absorbent material (shredded wood pulp).

APPENDIX G

SAFETY PINS IN MENSTRUAL PRODUCTS

Some patents illustrating safety pins or modifications of safety pins in their menstrual items are U.S. Patent No. 786,136 (Morison, 1905), U.S. Patent No. 813,176 (Schick, 1906), U.S. Patent No. 833,849 (Schiff, 1906), U.S. Patent No. 849,725 (Cook, 1907), U.S. Patent No. 880,928 (Slater, 1906), U.S. Patent No. 899,196 (Aiken, 1908), U.S. Patent No. 939,943 (Brodton, 1909), U.S. Patent No. 964,267 (Johnson, 1910), U.S. Patent No. 972,288 (Taylor, 1910), U.S. Patent No. 1,058,000 (Hosack & Hosack, 1913), U.S. Patent No. 1,110,674 (Des Rosiers, 1914), U.S. Patent No. 1,144,253 (Rubel, 1915), U.S. Patent No. 1,157,774 (Goodnou, 1915), U.S. Patent No. 1,159,362 (Cornell, 1915), U.S. Patent No. 1,169,490 (Joseph, 1916), U.S. Patent No. 1,300,510 (Steele, 1919), and U.S. Patent No. 1,388,529 (Smith, 1921).

APPENDIX H

CATAMENIAL GARMENTS

Enclosed or semi-enclosed catamenial garments are as follows:

Ignatius Wasserman, **Combined Catamenial Sack and Abdominal Supporter**, November 21, 1882, U.S.P. No. 267,956: enclosed front abdominal region, elastic thigh straps;

Emma Aubrey Wiley, **Catamenial Sack**, January 1, 1889, U.S.P. No. 395,411: thin rubber sack, enclosing front and rear abdominal region with openings for thighs; trough-shaped menstrual receptacle;

George R. Everson, **Catamenial Garment**, April 25, 1899, U.S.P. No. 623,658: half-drawers, enclosing the entire lower body with front-drop crotch piece that acts as menstrual carrier;

Sarah G. Schiff, **Catamenial Garment**, October 23, 1906, U.S.P. No. 833,849: one-piece garment comprising a pair of drawers with enlarged openings in the seat and abdominal regions, ties in leg openings for adjustment;

Anna L. Brodton, **Catamenial Garment**, November 9, 1909, U.S.P. No. 939,943: form-fitting garment cut from one piece of material and fastened at sides; when fastened, takes the shape of the body;

Grace Pfeil, **Sanitary Protector**, July 22, 1913, U.S.P. No. 1,067,841: "drawers" that cover the rear portion of the wearer only;

Jacob Rubel, **Catamenial Appliance**, June 22, 1915, U.S.P. No. 1,144,253: large triangular shield that fits lower torso completely and comes up through the crotch area to attach to a front yoke;

Cora E. Dudley, **Catamenial Sack**, December 24, 1918, U.S.P. No. 1,288,848: tailored, full length underpant that opens along front crotch line.

APPENDIX I

MENSTRUAL RETENTIVE CUPS

Catamenial Sack, U.S.P. No. 70,843, November 12, 1867, to S.L. Hockert: rubber sack attached to rubber ring;

Catamenial Sack, U.S.P. No. 182,024, September 12, 1876, to George E. Johnston: india rubber "receiving cup;"

Menstrual Receptacle, U.S.P. No. 300,770, June 24, 1884, to Hiram G. Farr: "elastic receptacle;"

Catamenial Sack or Menstrual Receptacle, U.S.P. No. 467,963, February 2, 1892, to Julius J. Vernier: vaginal cup;

Catamenial Sack, U.S.P. No. 535,980, March 19, 1895, to Philip W. Dautrich: vaginal ring and tube to support womb;

Catamenial Sack and Womb Supporter, U.S.P. No. 599,955, March 1, 1898, to Seth Beach: vaginal ring with a pendant sack;

Menstrual Receptacle, U.S.P. No. 642,265, January 30, 1900, to Byron B. Shea: vaginal receiver in shape of a tube, uses air suction to hold receiver in place;

Menstrual Receptacle and Uterine Supporter, U.S.P. No. 679,478, July 30, 1901, to Jacob R. Lang: hard rubber vaginal cup that combines functions of pessary, uterine supporter, and menstrual receptacle;

Catamenial Sack or Uterine Appliance, U.S.P. No. 737,258, August 25, 1903, Lee H. Mallalieu and Mildred Coke: ring connected to flexible sack;

Catamenial Device, U.S.P. No. 1,113,561, October 13, 1914, to John Jorgenson: non-corrosive metal vaginal cup; also acts as womb supporter;

Catamenial Appliance (2), U.S.P. No. 1,241,652 and 1,263,797, October 2, 1917 and April 23, 1918, respectively, to Lester E. Norquist: hard or soft vaginal cup.

APPENDIX J

LIST OF ASSIGNED PATENTS

U.S.P. No. 23,059, February 22, 1859, Charles E. Clark, Boston, Massachusetts, to himself and Geo. W. Clark of the same place;

U.S.P. No. 70,843, November 12, 1867, S.L. Hockert, Chicago, Illinois, to himself and Jared Thompson, Sr. of Milwaukee, Wisconsin;

U.S.P. No. #75,059, March 3, 1868, Charles Manheim, New York, New York, to E.L. Perry, of the same place (Perry was also a patentee: U.S.P. No. #49,915);

U.S.P. No. 78,414, June 2, 1868, Andrew F. Baum, New York, New York, to L.H. Rockwell of the same place;

U.S.P. No. #105,785, July 26, 1870, Warren A. Dinsmore, So. Boston, Massachusetts, to himself and Emily L. Geer, of the same place;

U.S.P. No. #162,647, April 27, 1875, Joseph H. Hatch, Melrose, Massachusetts, one-half to Joseph W. Spaulding of Richmond, Maine;

U.S.P. No. #205,912, July 9, 1878, Gustav Schilling, Chicago, Illinois, one-half to Carl Gottfried von Platen of the same place;

U.S.P. No. 393,408, November 27, 1888, William S. Watson, Matteawan, New York, one-half to Henry B. Bevier, of the same place;

U.S.P. No. #423,572, March 18, 1890, Ellen M. Preston of Providence, Rhode Island, one-half to Herbert I. Gould of the same place;

U.S.P. No. #478,053, June 28, 1892, Nelson M. Dyer of Louisville, Kentucky, to Alphonse Bourlier and Emile Bourlier of the same place;

U.S.P. No. #794,181, July 11, 1905, Herbert E. Hudson of Cleveland, Ohio, by Mesne Assignments to the Sanitary Shield and Manufacturing Co. of the same place;

U.S.P. No. #810,116 through #810,135, January 16, 1906, Willard Green of Muscatine, Iowa, to the Absorbent Fiber Company of Portland, Maine;

U.S.P. No. #811,704, June 6, 1906, Edward Savage Dix of New York, New York, to the Borated Specialty Company of Brooklyn, New York;

U.S.P. No. #901,742, October 20, 1908, Harriet M. Richards of Joliet, Illinois, to Woman's Mutual Benefit Company of the same place;

U.S.P. No. #903,895, November 17, 1908, Otto C. Schulz of Chicago, Illinois, to Bauer and Black Company of the same place;

U.S.P. No. 913,983, March 2, 1909, Paul J. Scheller and Norman I. Haas, Evansville, Indiana, one-third to Elias Horn of the same place;

U.S.P. No. #939,943, November 9, 1909, Anna L. Brodton of Mobile, Alabama, one half to Emile Tacon and Eva G. Tacon of the same place;

U.S.P. No. #976,883, November 19, 1910, Rudolph Keagy and Martin L. Keagy, of Canton, Ohio, one half to Daniel L. Holwick of the same place;

U.S.P. No. #1,144,253, June 22, 1915, Jacob Rubel of New York, New City, to Standard Mail Order Company of New York;

U.S.P. No. #1,150,572, August 17, 1915, Natalie Marjorie Barlet of New York City, to the Junoform Company (Goodwin B. Smith her attorney);

U.S.P. No. #1,158,182, October 26, 1915, Elfreda J. Corbin of Minneapolis, Minnesota, one half to Jennie Bohmbach of the same place;

U.S.P. No. #1,169,490, January 25, 1916, Ida M. Joseph of Chicago, Illinois, to Sol. H. Shoninger of the same place;

U.S.P. No. #1,192,439, July 25, 1916, Lawrence W. Luellen of Mountain Lakes, New Jersey to Individual Drinking Cup Co. of New York, a Maine Corporation;

U.S.P. No. #1,222,899, April 17, 1917, Goodwin B. Smith of Philadelphia, Pennsylvania, to Junoform Company;

U.S.P. No. 1,283,632, November 5, 1918, Joseph Beck of New York, New York, one-half to Walter Edelstein of So. Boston.

APPENDIX K

LIST OF PATENTS THAT MENTION DRESS OR FASHION

Some other patent texts that contain references to the development of a menstrual product and dress or the fashion silhouette are as follows: Griffith, 1904, U.S.P. No. #765,074; Coleman & Jarmulowsky, 1905, U.S.P. No. #780,598; Berry, 1907, U.S.P. No. #857,019; Aiken, 1908, U.S.P. No. #899,196; Johnson, 1910, U.S.P. No. #964,267; Argo, 1910, U.S.P. No. #979,730; Miller-Jones, 1911, U.S.P. No. #1,003,487; Hosack & Hosack, 1913, U.S.P. No. #1,058,000; Jordan, 1913, U.S.P. No. #1,064,836; Westfall, 1914, U.S.P. No. #1,100,108; Milkes, 1914, U.S.P. No. #1,108,206; Myers, 1914, U.S.P. No. #1,122,988; Rubel, 1915, U.S.P. No. #1,144,253; Corbin, 1915, U.S.P. No. #1,158,182; Cornell, 1915, U.S.P. No. #1,159,362; Alstyn, 1916, U.S.P. No. #1,175,090; Potter, 1916, U.S.P. No. 1,192,683; Dudley, 1918, U.S.P. No. #1,288,848.